

D  
C  
B  
A

D  
C  
B  
A

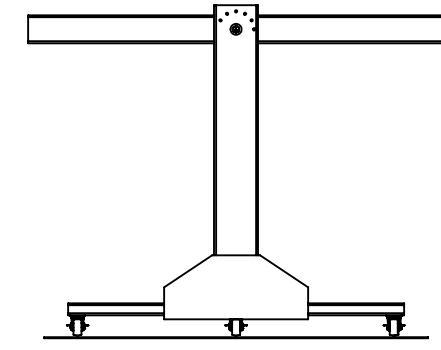
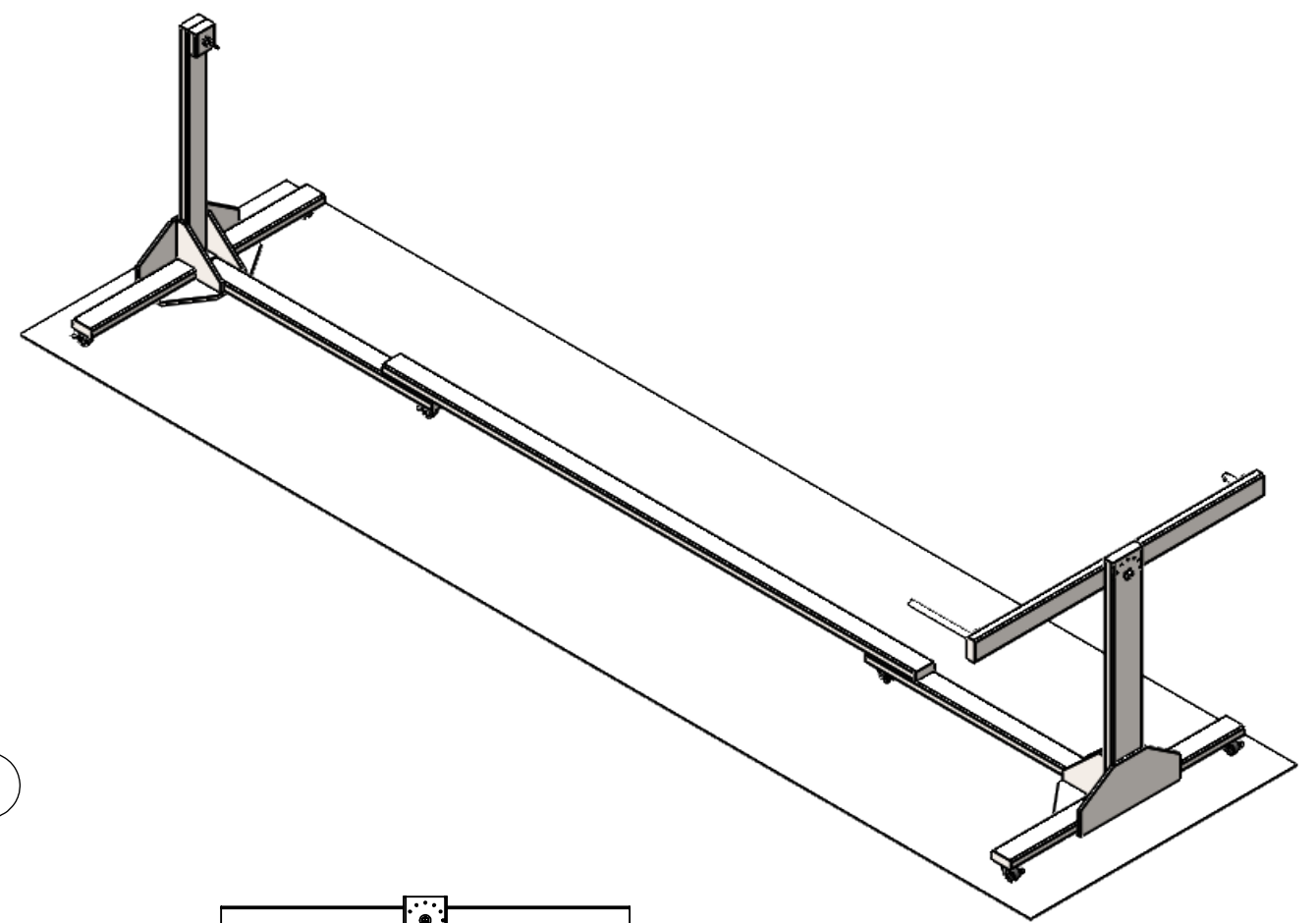
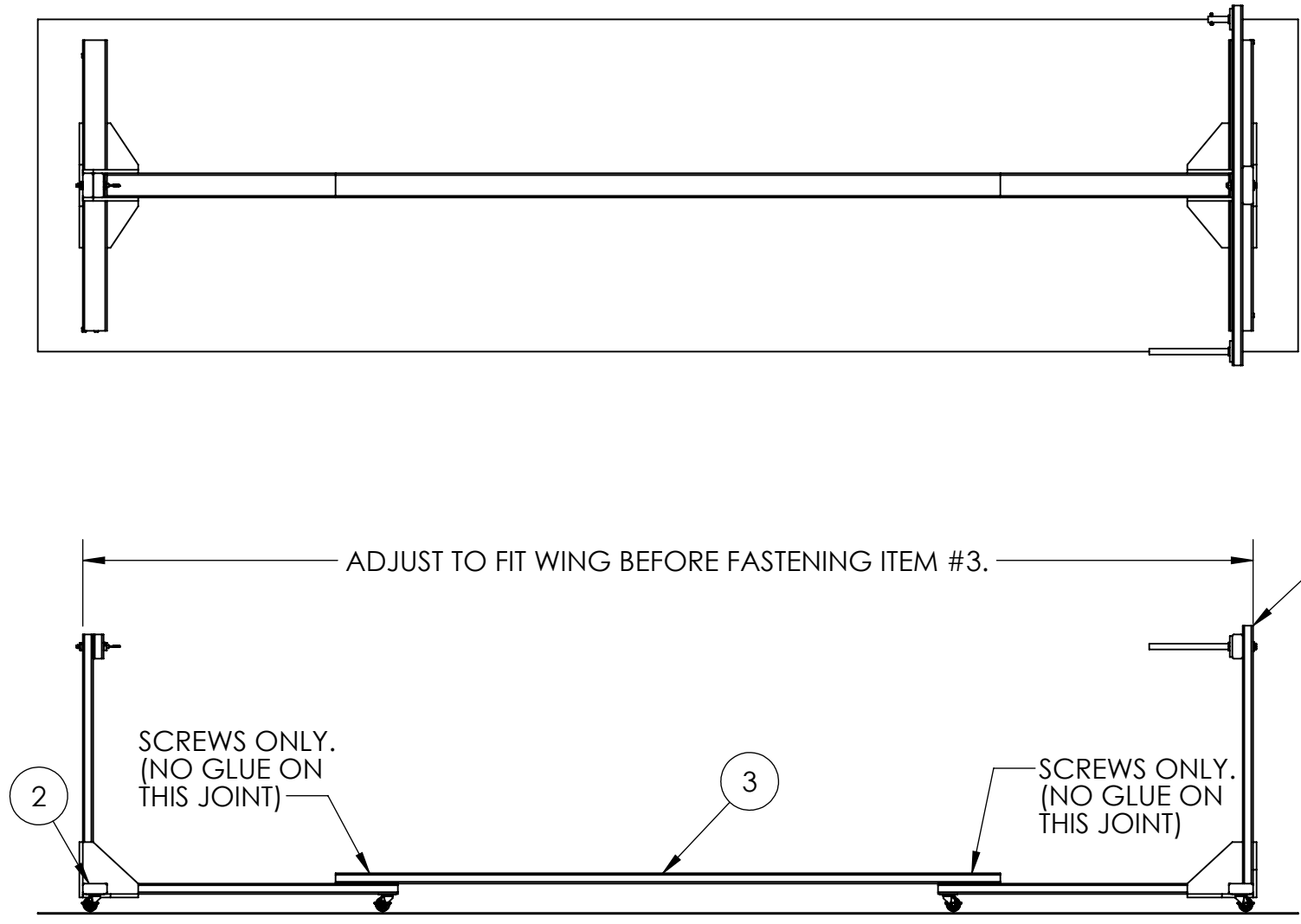

ITEM NO.	PART NUMBER	DESCRIPTION	QTY.
1	WS-102A	ASSY, ROOT STAND	1
2	WS-101A	ASSY, TIP STAND	1
3	2X4 - 96.00	2.00 X 4.00 X 96.00	1

UNLESS OTHERWISE SPECIFIED:  
 DIMENSIONS ARE IN INCHES  
 TOLERANCES:  
 FRACTIONAL ± 0.125  
 ANGULAR: ± 1 DEG  
 TWO PLACE DECIMAL ± 0.030  
 THREE PLACE DECIMAL ± 0.010  
 DO NOT SCALE DRAWING

**INNOVATION BY DESIGN**

TITLE:  
**ASSY, WING STANDS**

MATERIAL  
 SIZE **B** DWG. NO. **WS-100TL** REV **A**

SCALE: 1:24 WEIGHT: SHEET 1 OF 1

- NOTES:
- PLEASE EMAIL ANY NOTES OF ERRORS OR SUGGESTIONS TO STEVE AT INFO@IBDENG.COM.
  - AS AN ALTERNATIVE, IF FABRICATION OF ONLY A SINGLE SET OF STANDS IS DESIRED, FUSELAGE STAND #'S FS-103A AND FS-104A CAN BE SUBSTITUTED FOR THE WING STAND #'S WS-103A AND WS-104A. THIS WILL INCREASE THE HEIGHT OF THE WING STANDS 5.00".

**PROPRIETARY AND CONFIDENTIAL**  
 THE INFORMATION CONTAINED IN THIS DRAWING IS THE SOLE PROPERTY OF INNOVATION BY DESIGN AND/OR ITS DESIGNATED CLIENTS. ANY REPRODUCTION IN PART OR AS A WHOLE WITHOUT THE WRITTEN PERMISSION IS PROHIBITED.

	NAME	DATE
DRAWN	SDS	11/13/08
CHECKED		
ENG APPR.		
MFG APPR.		

8 7 6 5 4 3 2 1

D  
C  
B  
A

D  
C  
B  
A

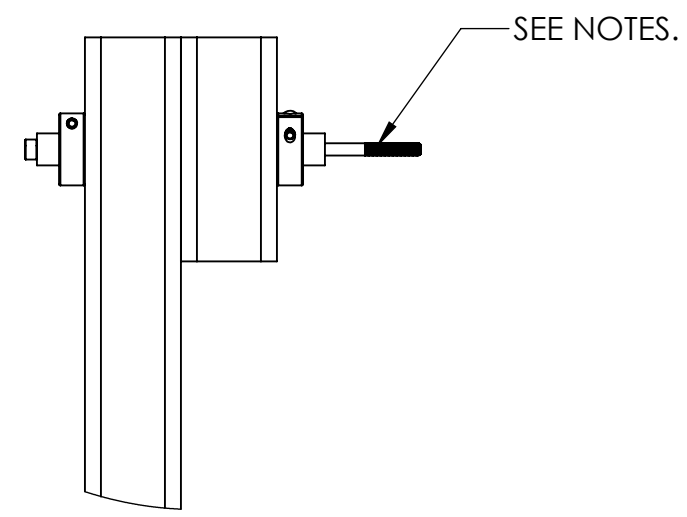
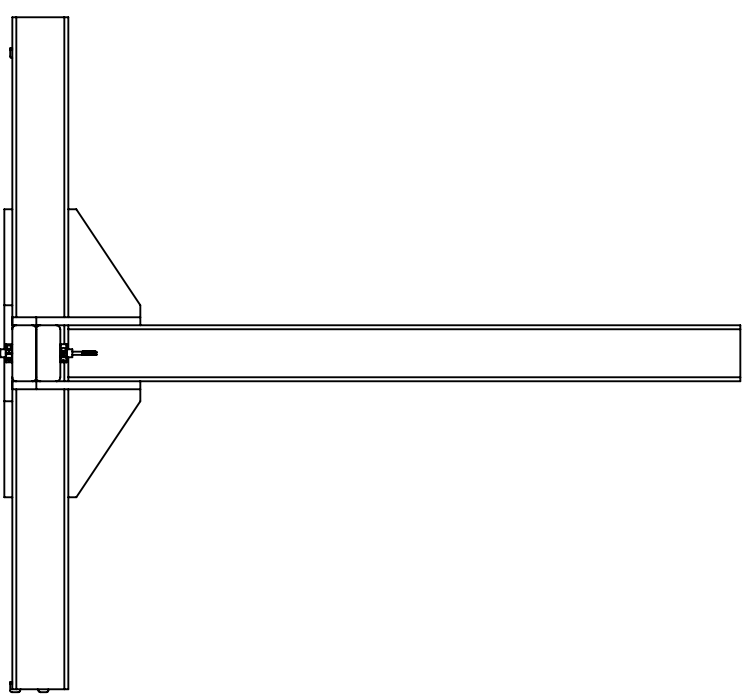

DETAIL A  
SCALE 1 : 3

SEE NOTES.

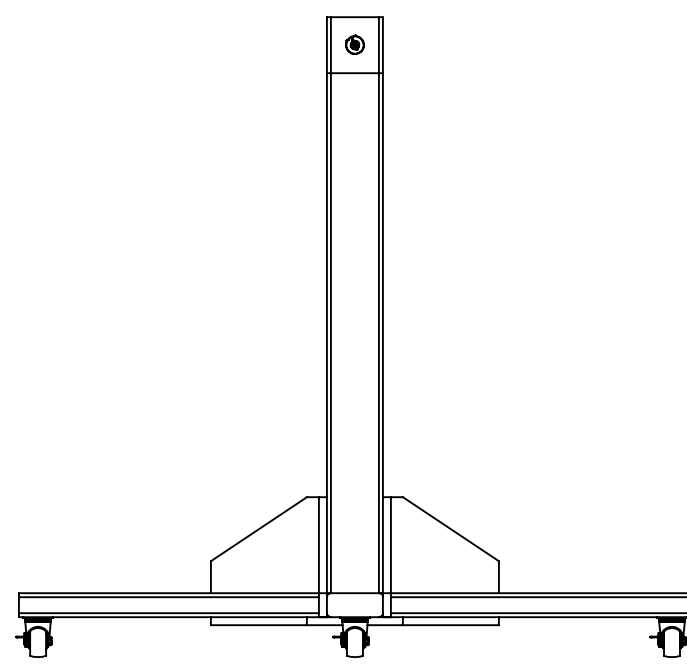
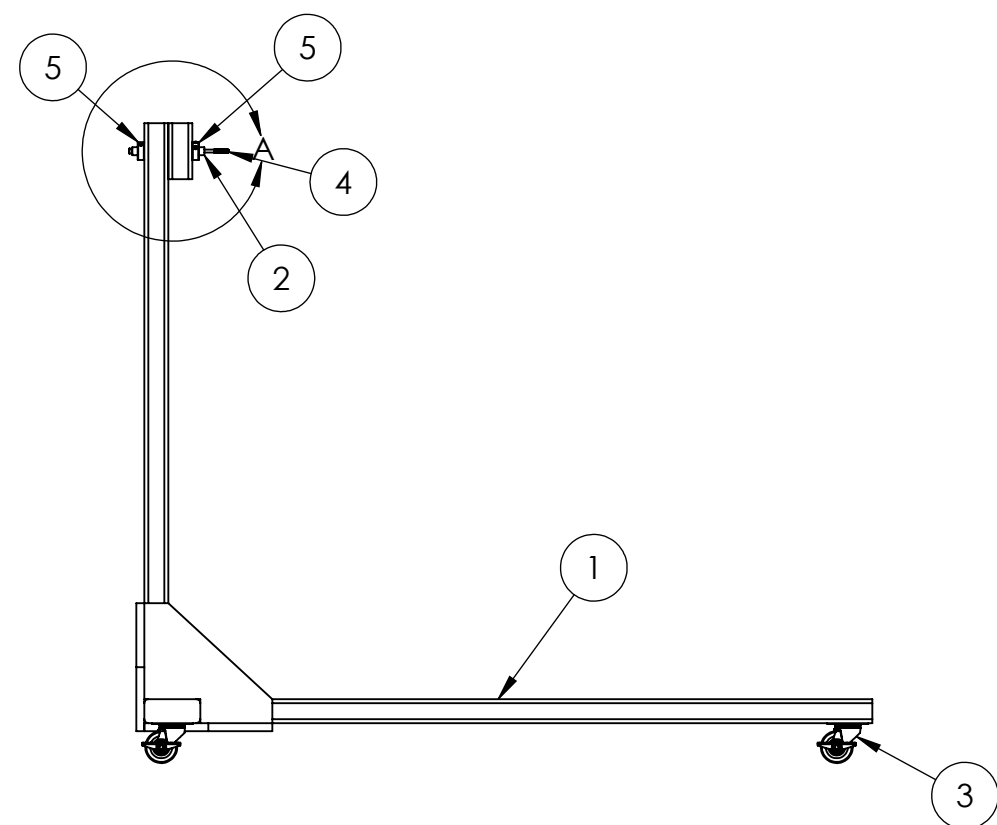
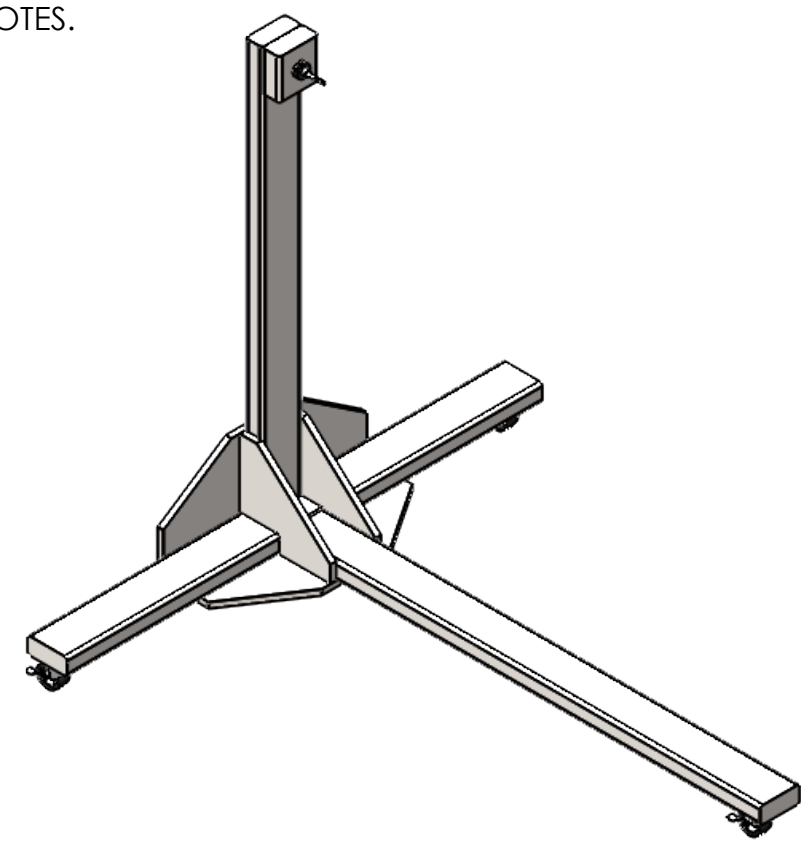

- NOTES:
- HAND TIGHTEN THE 10-32 BOLT INTO THE WING TIP NUT PLATE. THE PLASTIC TUBE SHOULD ROTATE FREELY IN THE WOOD STAND TO PREVENT UNTHREADING OF THE BOLT. THE COLLARS CAN BE ADJUSTED TO ALLOW FOR SOME ACCESS BETWEEN THE WING TIP AND THE WOODEN SUPPORTS FOR PAINTING ETC.

**PROPRIETARY AND CONFIDENTIAL**  
 THE INFORMATION CONTAINED IN THIS DRAWING IS THE SOLE PROPERTY OF INNOVATION BY DESIGN AND/OR ITS DESIGNATED CLIENTS. ANY REPRODUCTION IN PART OR AS A WHOLE WITHOUT THE WRITTEN PERMISSION IS PROHIBITED.

ITEM NO.	PART NUMBER	DESCRIPTION	QTY.
1	WS-103A	STAND, TIP	1
2	TUBE, .50X4.5	TUBE, .50 X .25 X 4.50	1
3	CASTER 2 IN	2" CASTER WHEEL ASSEMBLY	3
4	SCREW 10X6	SCREW, 10-32 X 6.00	1
5	COLLAR .50	COLLAR CLAMP, 1/2" ID.	2

UNLESS OTHERWISE SPECIFIED:  
 DIMENSIONS ARE IN INCHES  
 TOLERANCES:  
 FRACTIONAL ± 0.125  
 ANGULAR: ± 1 DEG  
 TWO PLACE DECIMAL ± 0.030  
 THREE PLACE DECIMAL ± 0.010  
 DO NOT SCALE DRAWING

**INNOVATION BY DESIGN**

TITLE:  
**ASSY, TIP STAND**

	NAME	DATE
DRAWN	SDS	11/13/08
CHECKED		
ENG APPR.		
MFG APPR.		

SIZE	DWG. NO.	REV
<b>B</b>	<b>WS-101A</b>	<b>A</b>
SCALE: 1:12	WEIGHT:	SHEET 1 OF 1

8 7 6 5 4 3 2 1

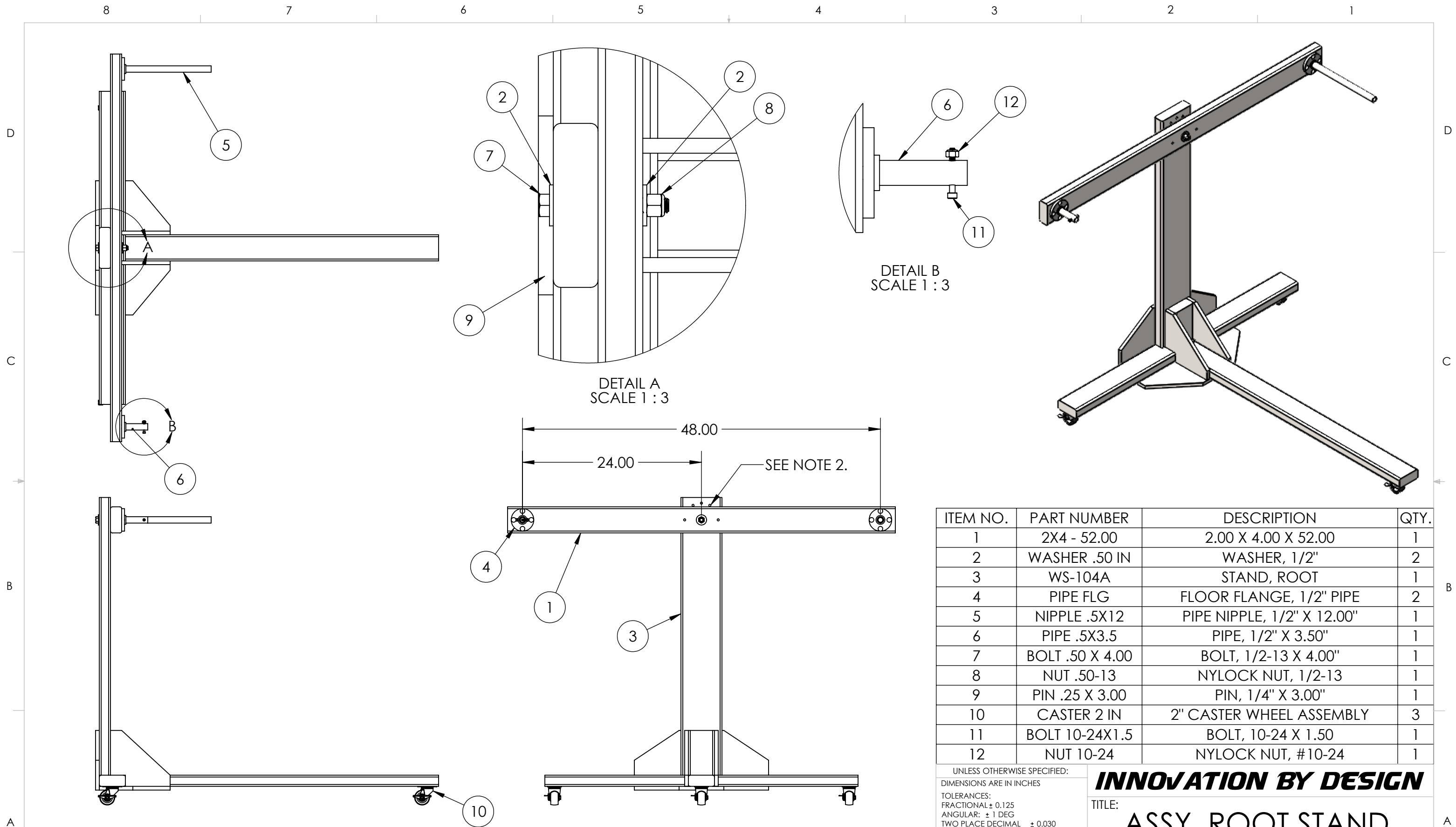

- NOTES:
1. ATTACH PIPE FLANGES AND CASTERS WITH #12 X 1.00 PAN HEAD SCREWS.
  2. REFER TO NOTE 1. ON DRAWING #WS-105DL FOR HOLE DRILLING PROCEDURE.

**PROPRIETARY AND CONFIDENTIAL**  
 THE INFORMATION CONTAINED IN THIS DRAWING IS THE SOLE PROPERTY OF INNOVATION BY DESIGN AND/OR ITS DESIGNATED CLIENTS. ANY REPRODUCTION IN PART OR AS A WHOLE WITHOUT THE WRITTEN PERMISSION IS PROHIBITED.

ITEM NO.	PART NUMBER	DESCRIPTION	QTY.
1	2X4 - 52.00	2.00 X 4.00 X 52.00	1
2	WASHER .50 IN	WASHER, 1/2"	2
3	WS-104A	STAND, ROOT	1
4	PIPE FLG	FLOOR FLANGE, 1/2" PIPE	2
5	NIPPLE .5X12	PIPE NIPPLE, 1/2" X 12.00"	1
6	PIPE .5X3.5	PIPE, 1/2" X 3.50"	1
7	BOLT .50 X 4.00	BOLT, 1/2-13 X 4.00"	1
8	NUT .50-13	NYLOCK NUT, 1/2-13	1
9	PIN .25 X 3.00	PIN, 1/4" X 3.00"	1
10	CASTER 2 IN	2" CASTER WHEEL ASSEMBLY	3
11	BOLT 10-24X1.5	BOLT, 10-24 X 1.50	1
12	NUT 10-24	NYLOCK NUT, #10-24	1

UNLESS OTHERWISE SPECIFIED:  
 DIMENSIONS ARE IN INCHES  
 TOLERANCES:  
 FRACTIONAL ± 0.125  
 ANGULAR: ± 1 DEG  
 TWO PLACE DECIMAL ± 0.030  
 THREE PLACE DECIMAL ± 0.010  
 DO NOT SCALE DRAWING

**INNOVATION BY DESIGN**  
 TITLE:  
**ASSY, ROOT STAND**

	NAME	DATE
DRAWN	SDS	11/13/08
CHECKED		
ENG APPR.		
MFG APPR.		

SIZE	DWG. NO.	REV
<b>B</b>	<b>WS-102A</b>	<b>A</b>
SCALE: 1:12	WEIGHT:	SHEET 1 OF 1

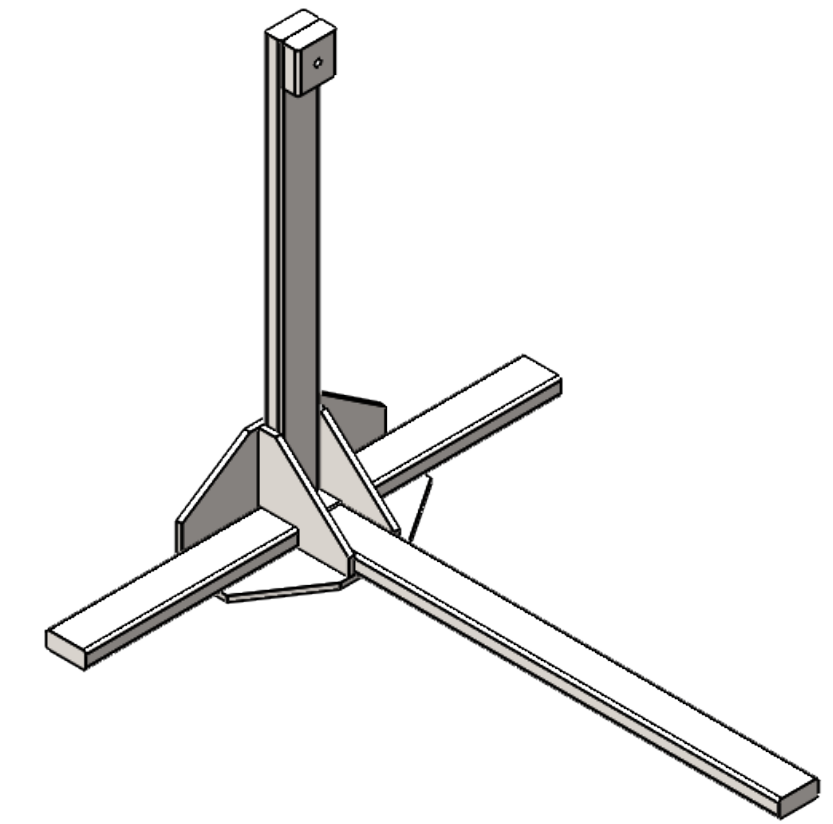
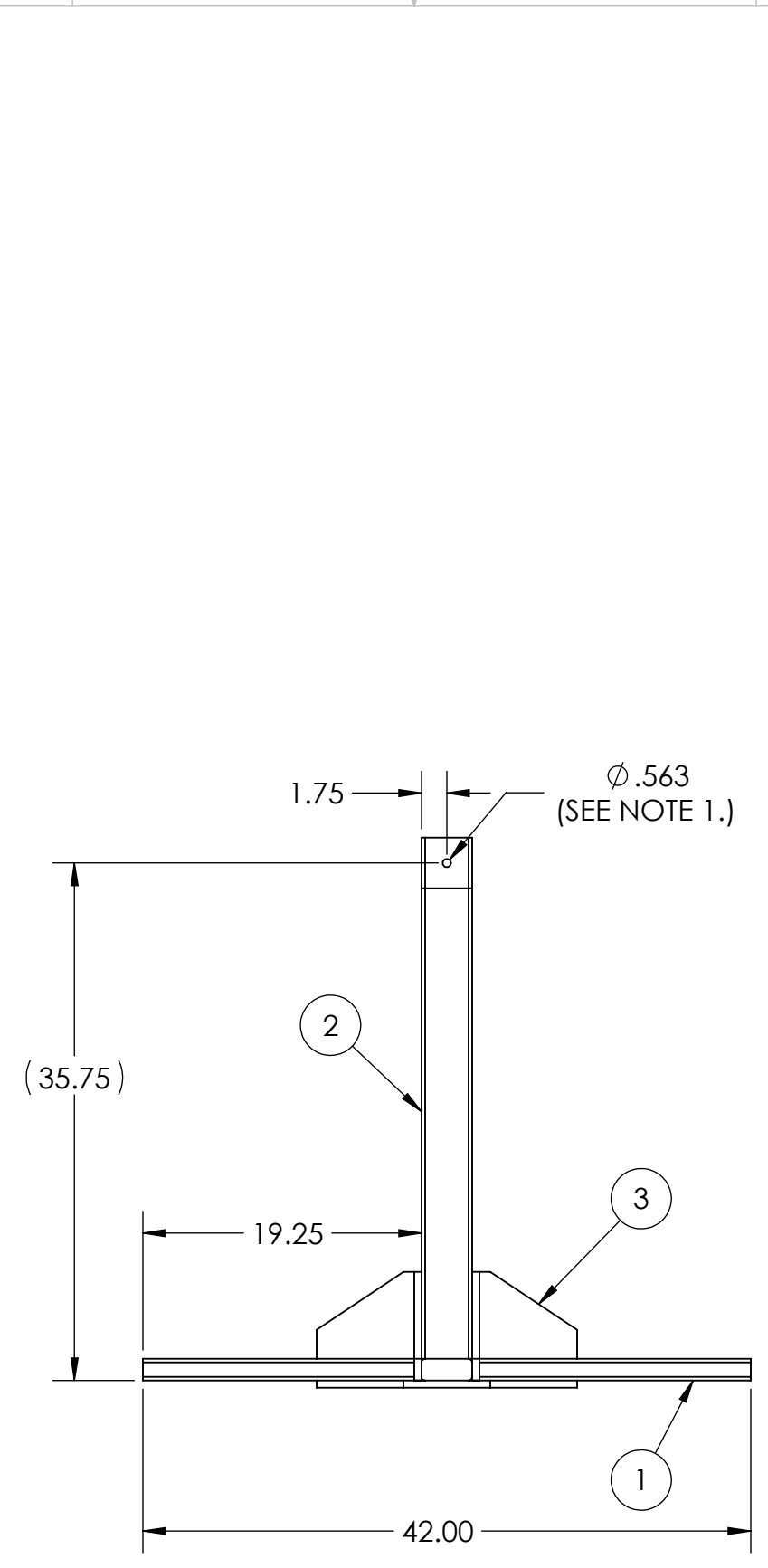
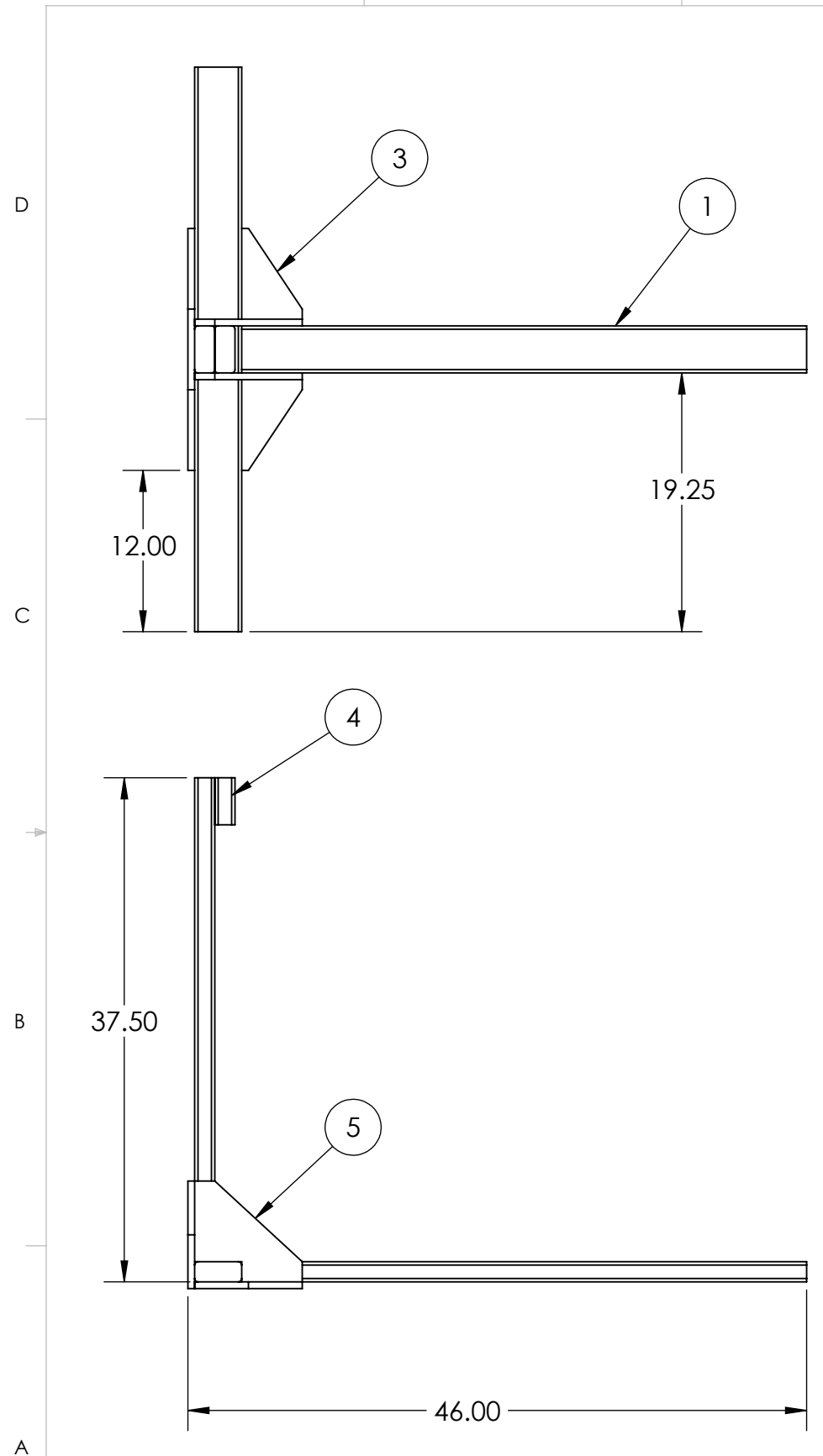

ITEM NO.	PART NUMBER	DESCRIPTION	QTY.
1	2X4 - 42.00	2.00 X 4.00 X 42.00	2
2	2X4 - 36.00	2.00 X 4.00 X 36.00	1
3	GUSSET 1	GUSSET 1	2
4	2X4 - 3.50	2.00 X 4.00 X 3.50	1
5	GUSSET 2	GUSSET 2	2

UNLESS OTHERWISE SPECIFIED:  
 DIMENSIONS ARE IN INCHES  
 TOLERANCES:  
 FRACTIONAL  $\pm 0.125$   
 ANGULAR:  $\pm 1$  DEG  
 TWO PLACE DECIMAL  $\pm 0.030$   
 THREE PLACE DECIMAL  $\pm 0.010$   
 DO NOT SCALE DRAWING

**INNOVATION BY DESIGN**

TITLE: **STAND, TIP**

MATERIAL:

	NAME	DATE
DRAWN	SDS	11/13/08
CHECKED		
ENG APPR.		
MFG APPR.		

SIZE	DWG. NO.	REV
<b>B</b>	<b>WS-103A</b>	<b>A</b>
SCALE: 1:12	WEIGHT:	SHEET 1 OF 1

- NOTES:
- TRANSFER DRILL  $\phi .563$  HOLE THROUGH 2.00 X 4.00 X 3.50 BLOCK AFTER ASSEMBLY.

**PROPRIETARY AND CONFIDENTIAL**  
 THE INFORMATION CONTAINED IN THIS DRAWING IS THE SOLE PROPERTY OF INNOVATION BY DESIGN AND/OR ITS DESIGNATED CLIENTS. ANY REPRODUCTION IN PART OR AS A WHOLE WITHOUT THE WRITTEN PERMISSION IS PROHIBITED.

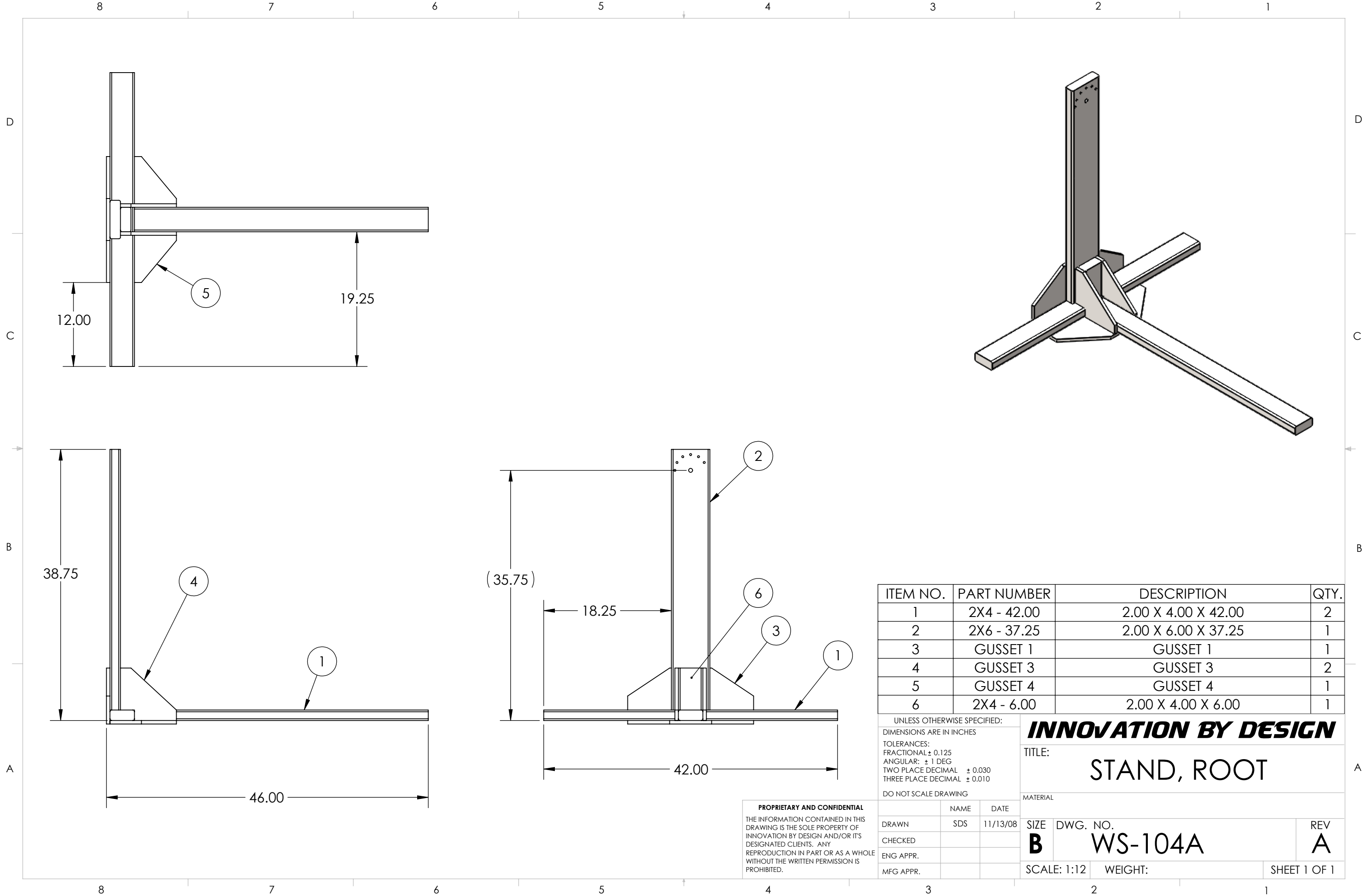

ITEM NO.	PART NUMBER	DESCRIPTION	QTY.
1	2X4 - 42.00	2.00 X 4.00 X 42.00	2
2	2X6 - 37.25	2.00 X 6.00 X 37.25	1
3	GUSSET 1	GUSSET 1	1
4	GUSSET 3	GUSSET 3	2
5	GUSSET 4	GUSSET 4	1
6	2X4 - 6.00	2.00 X 4.00 X 6.00	1

UNLESS OTHERWISE SPECIFIED:  
 DIMENSIONS ARE IN INCHES  
 TOLERANCES:  
 FRACTIONAL ± 0.125  
 ANGULAR: ± 1 DEG  
 TWO PLACE DECIMAL ± 0.030  
 THREE PLACE DECIMAL ± 0.010  
 DO NOT SCALE DRAWING

**INNOVATION BY DESIGN**  
 TITLE: **STAND, ROOT**  
 MATERIAL:

**PROPRIETARY AND CONFIDENTIAL**  
 THE INFORMATION CONTAINED IN THIS DRAWING IS THE SOLE PROPERTY OF INNOVATION BY DESIGN AND/OR ITS DESIGNATED CLIENTS. ANY REPRODUCTION IN PART OR AS A WHOLE WITHOUT THE WRITTEN PERMISSION IS PROHIBITED.

	NAME	DATE
DRAWN	SDS	11/13/08
CHECKED		
ENG APPR.		
MFG APPR.		

SIZE	DWG. NO.	REV
<b>B</b>	<b>WS-104A</b>	<b>A</b>
SCALE: 1:12	WEIGHT:	SHEET 1 OF 1

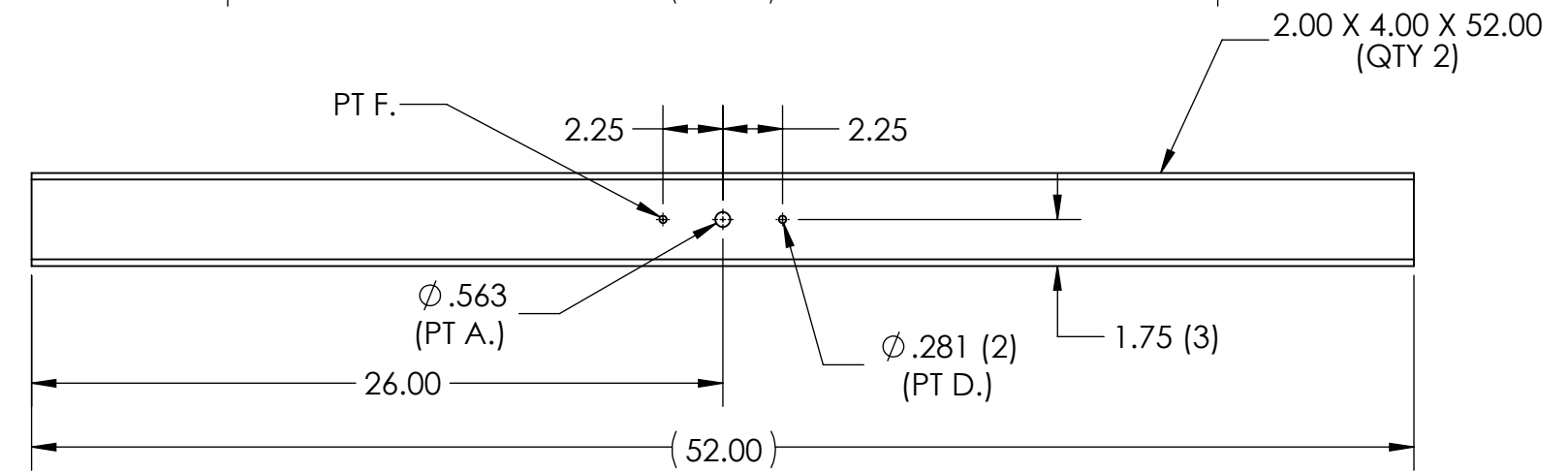
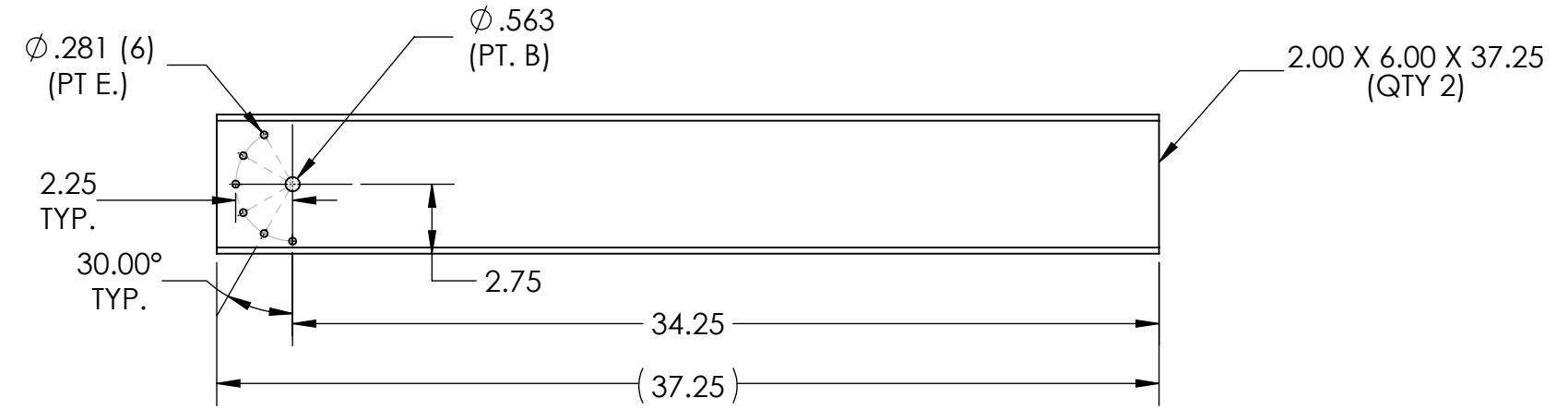
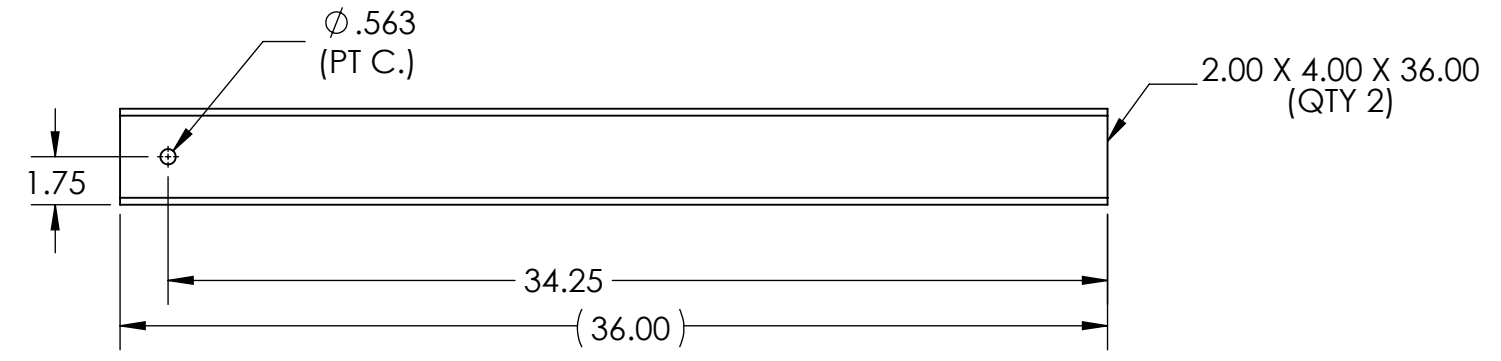
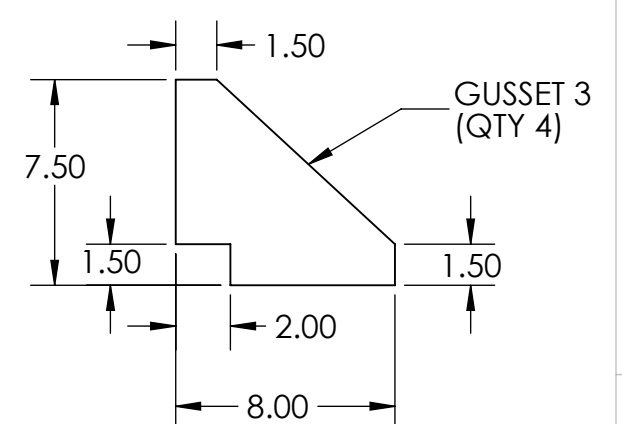
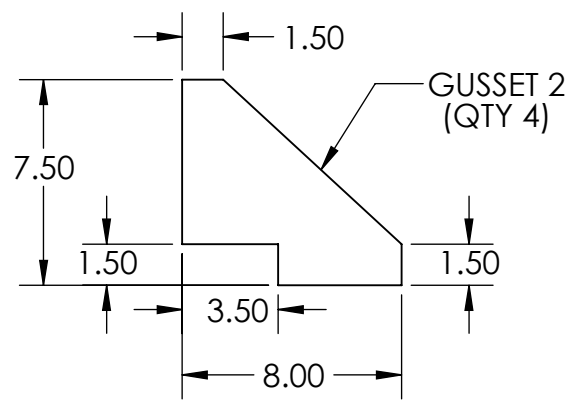
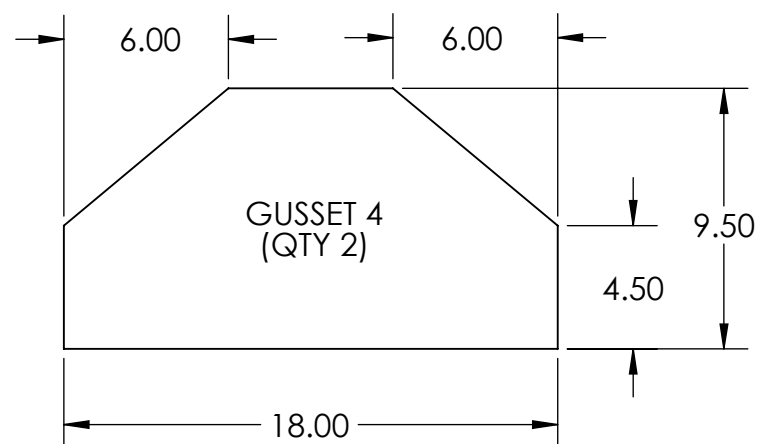
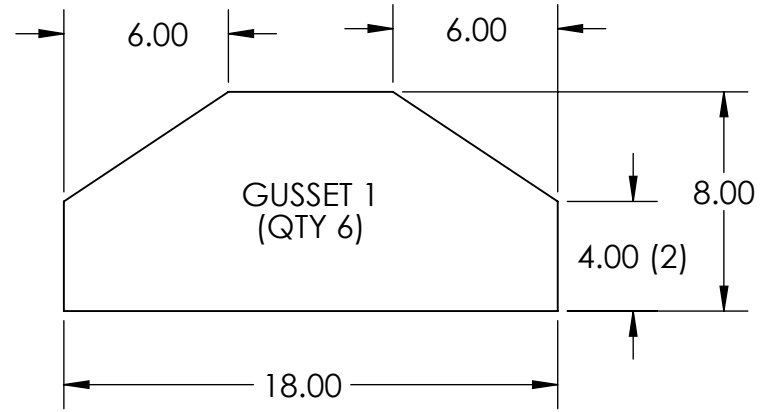
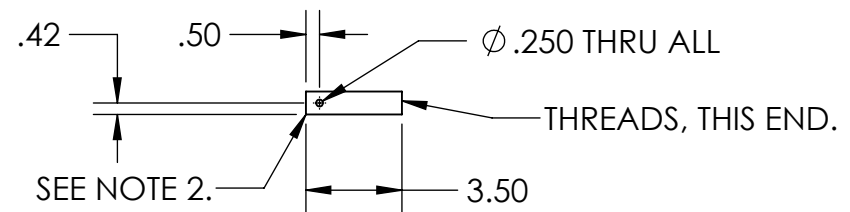

NOTES:

- MARK ALL HOLE LOCATIONS AND DRILL AS FOLLOWS:
  - DRILL Ø .563" HOLES AT POINT A., B. & C.
  - DRILL Ø .281" HOLE AT POINT D.
  - AFTER STANDS ARE ASSEMBLED, TRANSFER DRILL THROUGH HOLE AT POINT D. TO DEVELOP THE HOLE PATTERN AT POINT E.
  - TRANSFER DRILL THROUGH ONE OF THE POINT E. HOLES TO DEVELOP THE HOLE AT POINT F.
- MAKE QTY. 2 FROM ONE 12" PIPE NIPPLE.
- QUANTITIES LISTED WILL MAKE TWO SETS OF STANDS.

UNLESS OTHERWISE SPECIFIED:  
 DIMENSIONS ARE IN INCHES  
 TOLERANCES:  
 FRACTIONAL ± 0.125  
 ANGULAR: ± 1 DEG  
 TWO PLACE DECIMAL ± 0.030  
 THREE PLACE DECIMAL ± 0.010  
 DO NOT SCALE DRAWING

**INNOVATION BY DESIGN**

TITLE: **DIMENSION LIST**

**PROPRIETARY AND CONFIDENTIAL**  
 THE INFORMATION CONTAINED IN THIS DRAWING IS THE SOLE PROPERTY OF INNOVATION BY DESIGN AND/OR ITS DESIGNATED CLIENTS. ANY REPRODUCTION IN PART OR AS A WHOLE WITHOUT THE WRITTEN PERMISSION IS PROHIBITED.

	NAME	DATE
DRAWN	SDS	11/13/08
CHECKED		
ENG APPR.		
MFG APPR.		

MATERIAL		SIZE	DWG. NO.	REV
		<b>B</b>	<b>WS-105DL</b>	<b>A</b>
SCALE: 1:7		WEIGHT:		SHEET 1 OF 1

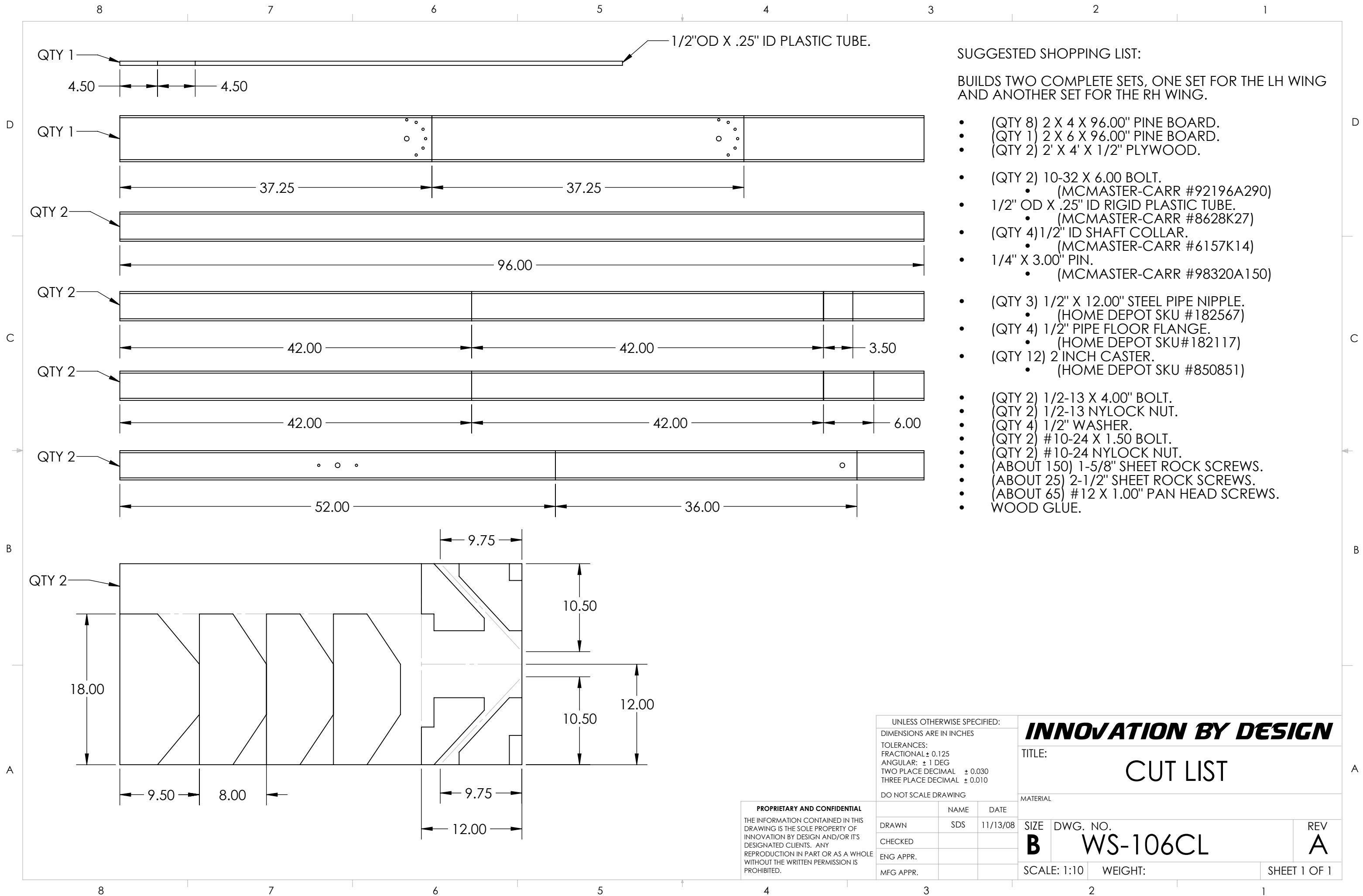

1/2"OD X .25" ID PLASTIC TUBE.

SUGGESTED SHOPPING LIST:

BUILDS TWO COMPLETE SETS, ONE SET FOR THE LH WING AND ANOTHER SET FOR THE RH WING.

- (QTY 8) 2 X 4 X 96.00" PINE BOARD.
- (QTY 1) 2 X 6 X 96.00" PINE BOARD.
- (QTY 2) 2' X 4' X 1/2" PLYWOOD.
  
- (QTY 2) 10-32 X 6.00 BOLT.
  - (MCMASTER-CARR #92196A290)
- 1/2" OD X .25" ID RIGID PLASTIC TUBE.
  - (MCMASTER-CARR #8628K27)
- (QTY 4) 1/2" ID SHAFT COLLAR.
  - (MCMASTER-CARR #6157K14)
- 1/4" X 3.00" PIN.
  - (MCMASTER-CARR #98320A150)
  
- (QTY 3) 1/2" X 12.00" STEEL PIPE NIPPLE.
  - (HOME DEPOT SKU #182567)
- (QTY 4) 1/2" PIPE FLOOR FLANGE.
  - (HOME DEPOT SKU#182117)
- (QTY 12) 2 INCH CASTER.
  - (HOME DEPOT SKU #850851)
  
- (QTY 2) 1/2-13 X 4.00" BOLT.
- (QTY 2) 1/2-13 NYLOCK NUT.
- (QTY 4) 1/2" WASHER.
- (QTY 2) #10-24 X 1.50 BOLT.
- (QTY 2) #10-24 NYLOCK NUT.
- (ABOUT 150) 1-5/8" SHEET ROCK SCREWS.
- (ABOUT 25) 2-1/2" SHEET ROCK SCREWS.
- (ABOUT 65) #12 X 1.00" PAN HEAD SCREWS.
- WOOD GLUE.

UNLESS OTHERWISE SPECIFIED:  
 DIMENSIONS ARE IN INCHES  
 TOLERANCES:  
 FRACTIONAL ± 0.125  
 ANGULAR: ± 1 DEG  
 TWO PLACE DECIMAL ± 0.030  
 THREE PLACE DECIMAL ± 0.010  
 DO NOT SCALE DRAWING

**INNOVATION BY DESIGN**

TITLE:  
**CUT LIST**

**PROPRIETARY AND CONFIDENTIAL**  
 THE INFORMATION CONTAINED IN THIS DRAWING IS THE SOLE PROPERTY OF INNOVATION BY DESIGN AND/OR ITS DESIGNATED CLIENTS. ANY REPRODUCTION IN PART OR AS A WHOLE WITHOUT THE WRITTEN PERMISSION IS PROHIBITED.

	NAME	DATE
DRAWN	SDS	11/13/08
CHECKED		
ENG APPR.		
MFG APPR.		

MATERIAL		SIZE	DWG. NO.	REV
		<b>B</b>	<b>WS-106CL</b>	<b>A</b>
SCALE: 1:10		WEIGHT:		SHEET 1 OF 1