

NOTE:
I USED STAPLES TO INSTALL HEAVY PLASTIC SHEETING TO THE INTERIOR, AND THEN CAME BACK AND STAPLED LATHE OVER THE PLASTIC TO ADD SOME EXTRA SUPPORT.

ITEM NO.	PART NUMBER	DESCRIPTION	QTY.
1	BOOTH FRAME		1
2	DOOR		2
3	2x4 - 91.00		1
4	2x4 - 7.00		2
5	GUSSET 3		2
6	PPL DOOR	HOME DEPOT WCEN36PG	1
7	FLOOR 1	96.00X48.00 (HOME DEPOT #346428)	4
8	FLOOR 2	48.00X44.00 (HOME DEPOT #346428)	4
9	FLOOR 3	96.00X27.00 (HOME DEPOT #346428)	1
10	FLOOR 4	44.00X27.00 (HOME DEPOT #346428)	1

NOTES:
I PREPARED THESE DRAWINGS DURING THE DEVELOPMENT OF MY OWN PAINT BOOTH, WHICH WAS DESIGNED TO FIT THE SPACE AND FACILITIES I HAD AVAILABLE.
THE DRAWINGS WERE INTENDED TO BE A GOOD STARTING POINT, BUT EVEN AS I CONSTRUCTED MY BOOTH I MADE SOME CHANGES ON THE FLY. PLEASE FEEL FREE TO MODIFY TO SUIT YOUR OWN INDIVIDUAL NEEDS.
ONE ITEM TO NOTE IS THAT THE 226.00" LENGTH OF MY BOOTH WAS SET TO FIT MY AVAILABLE SHOP SPACE, AND WHILE THE S-20 FUSELAGE FITS, IT IS TIGHT. INCREASING THIS LENGTH MAY BE BENEFICIAL FOR ALLOWING SPACE TO WALK AROUND THE ENDS OF THE FUSELAGE WHILE IN FULL PAINT GEAR.

-- STEVE

PROPRIETARY AND CONFIDENTIAL
THE INFORMATION CONTAINED IN THIS DRAWING IS THE SOLE PROPERTY OF INNOVATION BY DESIGN AND/OR ITS DESIGNATED CLIENTS. ANY REPRODUCTION IN PART OR AS A WHOLE WITHOUT THE WRITTEN PERMISSION IS PROHIBITED.

UNLESS OTHERWISE SPECIFIED:
DIMENSIONS ARE IN INCHES
TOLERANCES:
FRACTIONAL ± 0.125
ANGULAR: ± 1 DEG
TWO PLACE DECIMAL ± 0.030
THREE PLACE DECIMAL ± 0.010
DO NOT SCALE DRAWING

	NAME	DATE
DRAWN	SDS	11/13/08
CHECKED		
ENG APPR.		
MFG APPR.		

INNOVATION BY DESIGN

TITLE:
PAINT BOOTH ASSY.

MATERIAL

SIZE	DWG. NO.	REV
B	PAINT BOOTH ASSY	A

SCALE: 1:48 WEIGHT: SHEET 1 OF 1

8 7 6 5 4 3 2 1

D

C

B

A

D

C

B

A

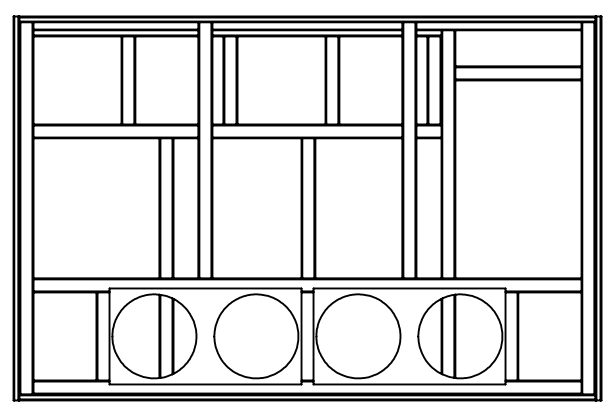
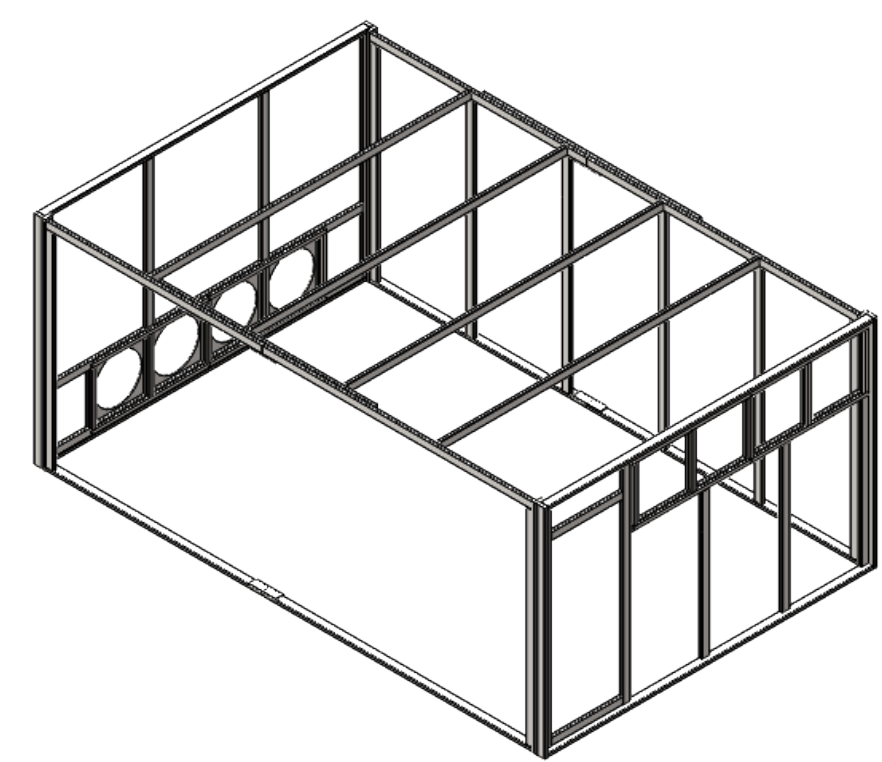
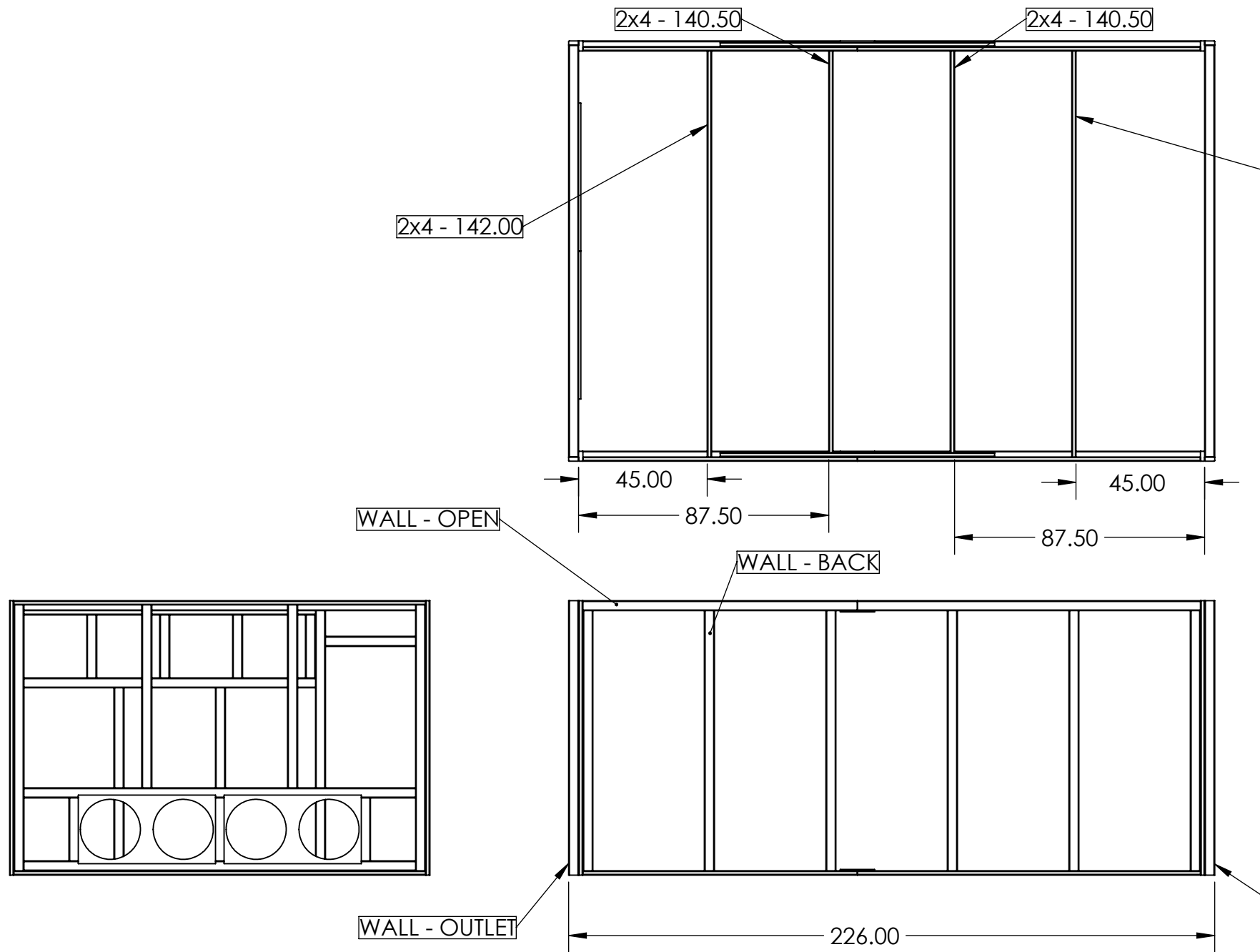

WALL - OUTLET

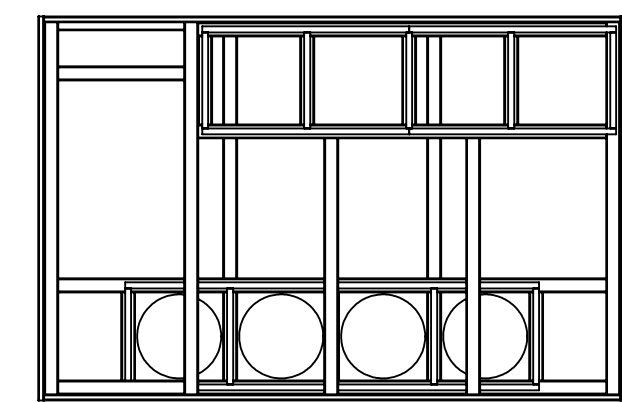

WALL - INLET

ITEM NO.	PART NUMBER	DESCRIPTION	QTY.
1	WALL - OPEN		1
2	WALL - BACK		1
3	2x4 - 142.00		2
4	WALL - INLET		1
5	2x4 - 140.50		2
6	WALL - OUTLET		1

UNLESS OTHERWISE SPECIFIED:
 DIMENSIONS ARE IN INCHES
 TOLERANCES:
 FRACTIONAL ± 0.125
 ANGULAR: ± 1 DEG
 TWO PLACE DECIMAL ± 0.030
 THREE PLACE DECIMAL ± 0.010
 DO NOT SCALE DRAWING

INNOVATION BY DESIGN

	NAME	DATE
DRAWN	SDS	11/13/08
CHECKED		
ENG APPR.		
MFG APPR.		

TITLE:		MATERIAL:	
SIZE	DWG. NO.	REV	
B BOOTH FRAME		A	
SCALE: 1:48	WEIGHT:	SHEET 1 OF 1	

NOTES:
 1. FLUSH SIDES FACE INWARDS.

PROPRIETARY AND CONFIDENTIAL
 THE INFORMATION CONTAINED IN THIS DRAWING IS THE SOLE PROPERTY OF INNOVATION BY DESIGN AND/OR ITS DESIGNATED CLIENTS. ANY REPRODUCTION IN PART OR AS A WHOLE WITHOUT THE WRITTEN PERMISSION IS PROHIBITED.

8 7 6 5 4 3 2 1

8 7 6 5 4 3 2 1

D

C

B

A

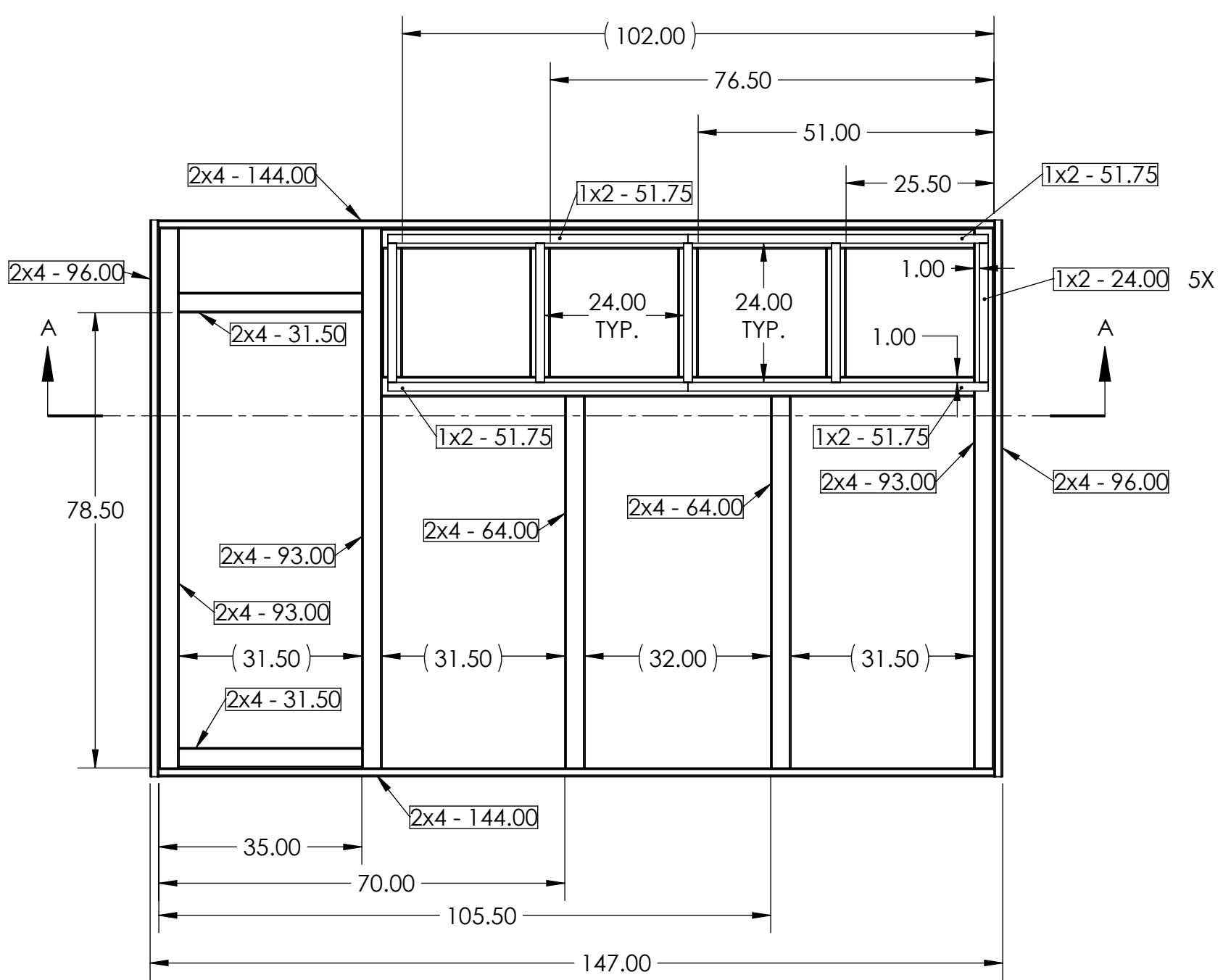
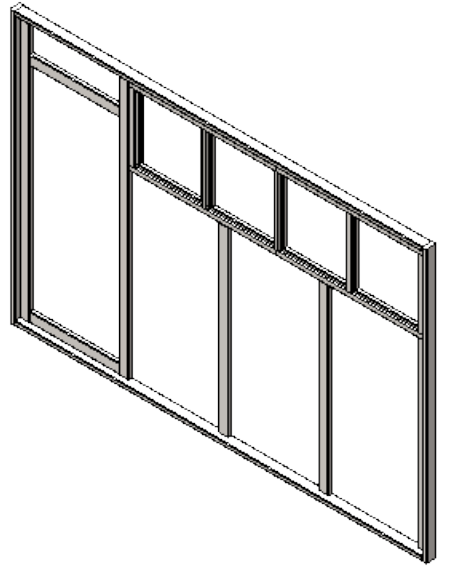
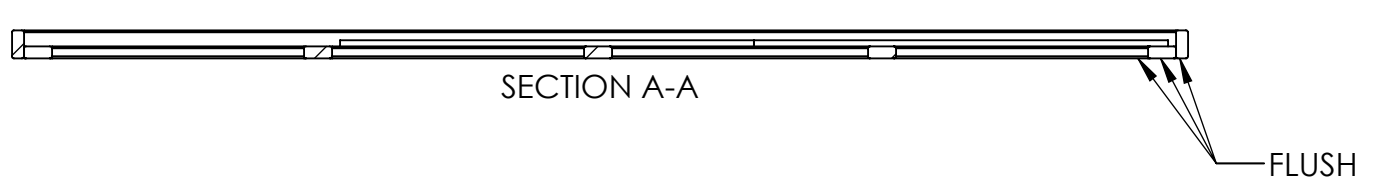

- NOTES:
- USE DUCT TAPE TO INSTALL FOUR 24 X 24 FURNACE FILTERS.

ITEM NO.	PART NUMBER	DESCRIPTION	QTY.
1	2x4 - 144.00		2
2	2x4 - 96.00		2
3	2x4 - 93.00		3
4	2x4 - 31.50		2
5	2x4 - 102.00		2
6	2x4 - 22.00		4
7	1x2 - 24.00		5
8	1x2 - 51.75		4
9	2x4 - 64.00		2

UNLESS OTHERWISE SPECIFIED:
 DIMENSIONS ARE IN INCHES
 TOLERANCES:
 FRACTIONAL ± 0.125
 ANGULAR: ± 1 DEG
 TWO PLACE DECIMAL ± 0.030
 THREE PLACE DECIMAL ± 0.010
 DO NOT SCALE DRAWING

INNOVATION BY DESIGN
 TITLE:
 MATERIAL:

PROPRIETARY AND CONFIDENTIAL
 THE INFORMATION CONTAINED IN THIS DRAWING IS THE SOLE PROPERTY OF INNOVATION BY DESIGN AND/OR ITS DESIGNATED CLIENTS. ANY REPRODUCTION IN PART OR AS A WHOLE WITHOUT THE WRITTEN PERMISSION IS PROHIBITED.

	NAME	DATE
DRAWN	SDS	11/13/08
CHECKED		
ENG APPR.		
MFG APPR.		

SIZE DWG. NO. REV
B **WALL - INLET** **A**
 SCALE: 1:24 WEIGHT: SHEET 1 OF 1

8 7 6 5 4 3 2 1

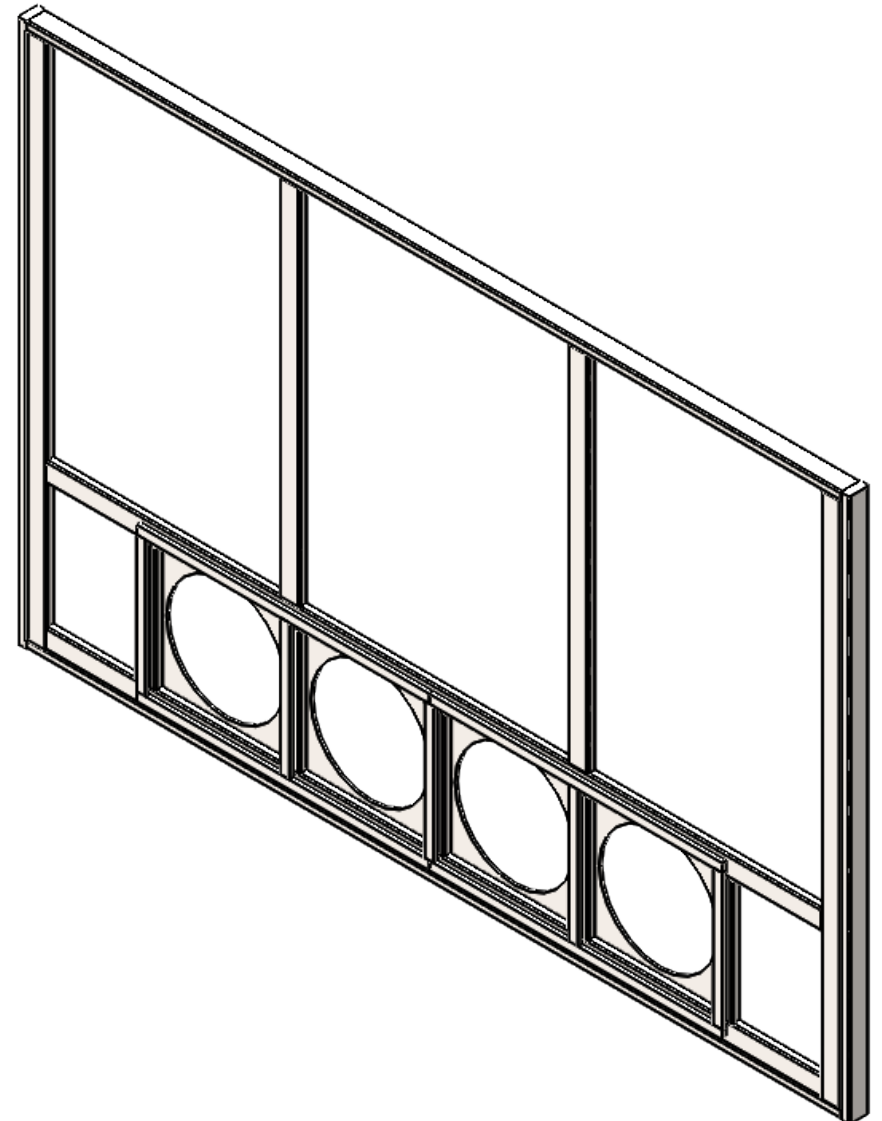
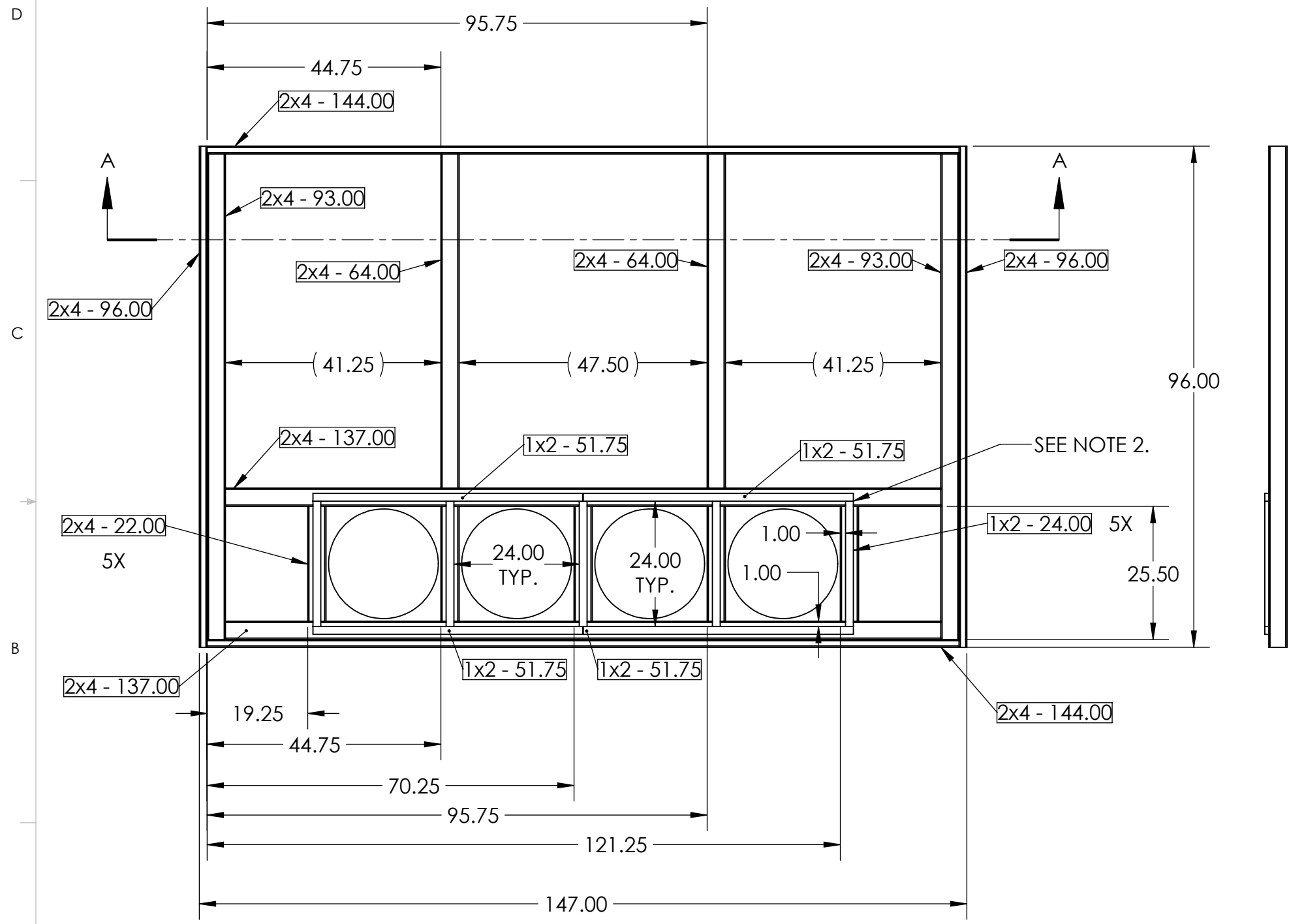

ITEM NO.	PART NUMBER	DESCRIPTION	QTY.
1	2x4 - 144.00		2
2	2x4 - 96.00		2
3	2x4 - 93.00		2
4	2x4 - 137.00		2
5	2x4 - 22.00		5
6	2x4 - 64.00		2
7	1x2 - 24.00		5
8	1x2 - 51.75		4
9	MOUNT - BOX FAN		2

- NOTES:
- SEAL ALL GAPS WITH DUCT TAPE.
 - THE 1X2'S ALLOW FURNACE FILTERS TO BE USED. IN MY CASE I SWITCHED TO WINDOW SCREEN AFTER THE FILTERS QUICKLY PLUGGED. IF FILTERS ARE NOT EXPECTED TO BE USED THE 1X2'S CAN BE ELIMINATED FROM THIS WALL. THIS WILL DEPEND ON THE SIZE OF THE BUGS IN YOUR AREA, AND IF YOU CAN WITHSTAND OVERSPRAY EXITING THE PAINT BOOTH.

PROPRIETARY AND CONFIDENTIAL
 THE INFORMATION CONTAINED IN THIS DRAWING IS THE SOLE PROPERTY OF INNOVATION BY DESIGN AND/OR ITS DESIGNATED CLIENTS. ANY REPRODUCTION IN PART OR AS A WHOLE WITHOUT THE WRITTEN PERMISSION IS PROHIBITED.

UNLESS OTHERWISE SPECIFIED:
 DIMENSIONS ARE IN INCHES
 TOLERANCES:
 FRACTIONAL ± 0.125
 ANGULAR: ± 1 DEG
 TWO PLACE DECIMAL ± 0.030
 THREE PLACE DECIMAL ± 0.010
 DO NOT SCALE DRAWING

	NAME	DATE
DRAWN	SDS	11/13/08
CHECKED		
ENG APPR.		
MFG APPR.		

INNOVATION BY DESIGN

TITLE:
B WALL - OUTLET

MATERIAL:

SCALE: 1:24 WEIGHT: SHEET 1 OF 2

REV **A**

8 7 6 5 4 3 2 1

D
C
B
A

D
C
B
A

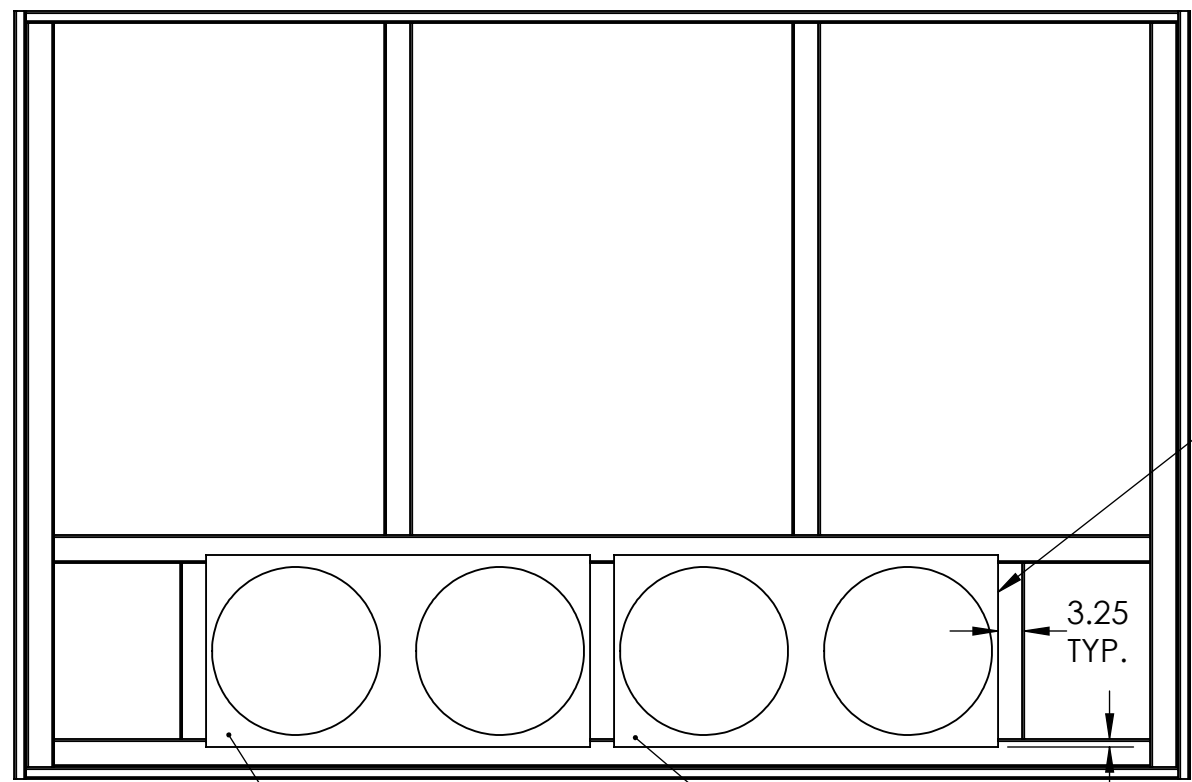

MOUNT - BOX FAN

MOUNT - BOX FAN

SEE NOTE 1.

3.25
TYP.

1.00 TYP.

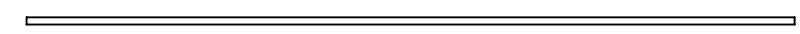

Ø 21.00
TYP.

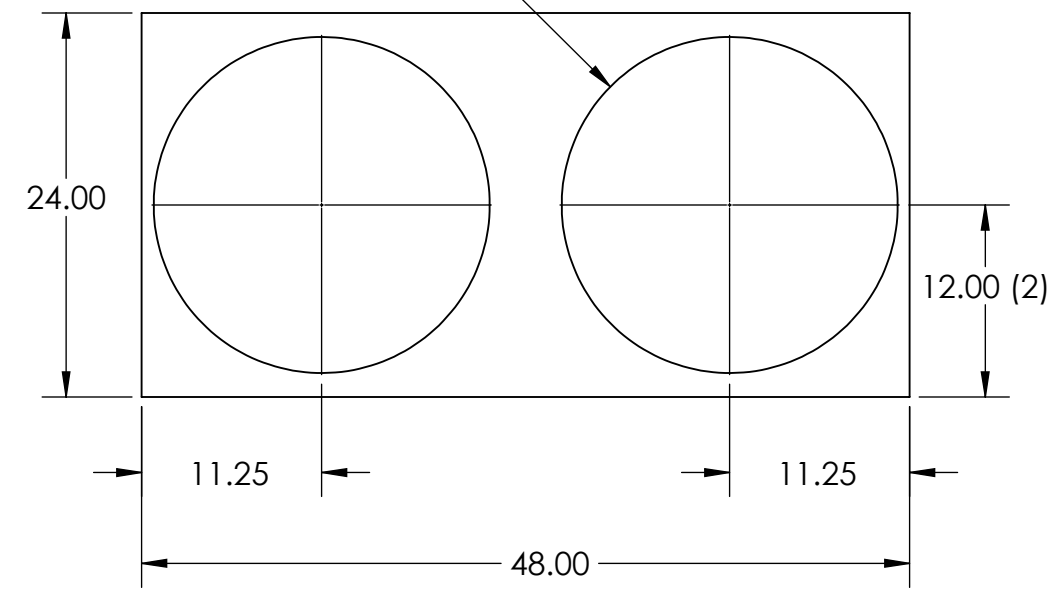

MOUNT - BOX FAN
(2 REQ'D)

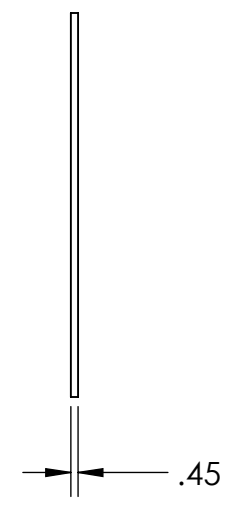

.45

UNLESS OTHERWISE SPECIFIED:
DIMENSIONS ARE IN INCHES
TOLERANCES:
FRACTIONAL ± 0.125
ANGULAR: ± 1 DEG
TWO PLACE DECIMAL ± 0.030
THREE PLACE DECIMAL ± 0.010
DO NOT SCALE DRAWING

INNOVATION BY DESIGN

TITLE:

MATERIAL

PROPRIETARY AND CONFIDENTIAL
THE INFORMATION CONTAINED IN THIS DRAWING IS THE SOLE PROPERTY OF INNOVATION BY DESIGN AND/OR ITS DESIGNATED CLIENTS. ANY REPRODUCTION IN PART OR AS A WHOLE WITHOUT THE WRITTEN PERMISSION IS PROHIBITED.

	NAME	DATE
DRAWN	SDS	11/24/08
CHECKED		
ENG APPR.		
MFG APPR.		

SIZE DWG. NO. REV
B WALL - OUTLET **A**

SCALE: 1:24 WEIGHT: SHEET 2 OF 2

8 7 6 5 4 3 2 1

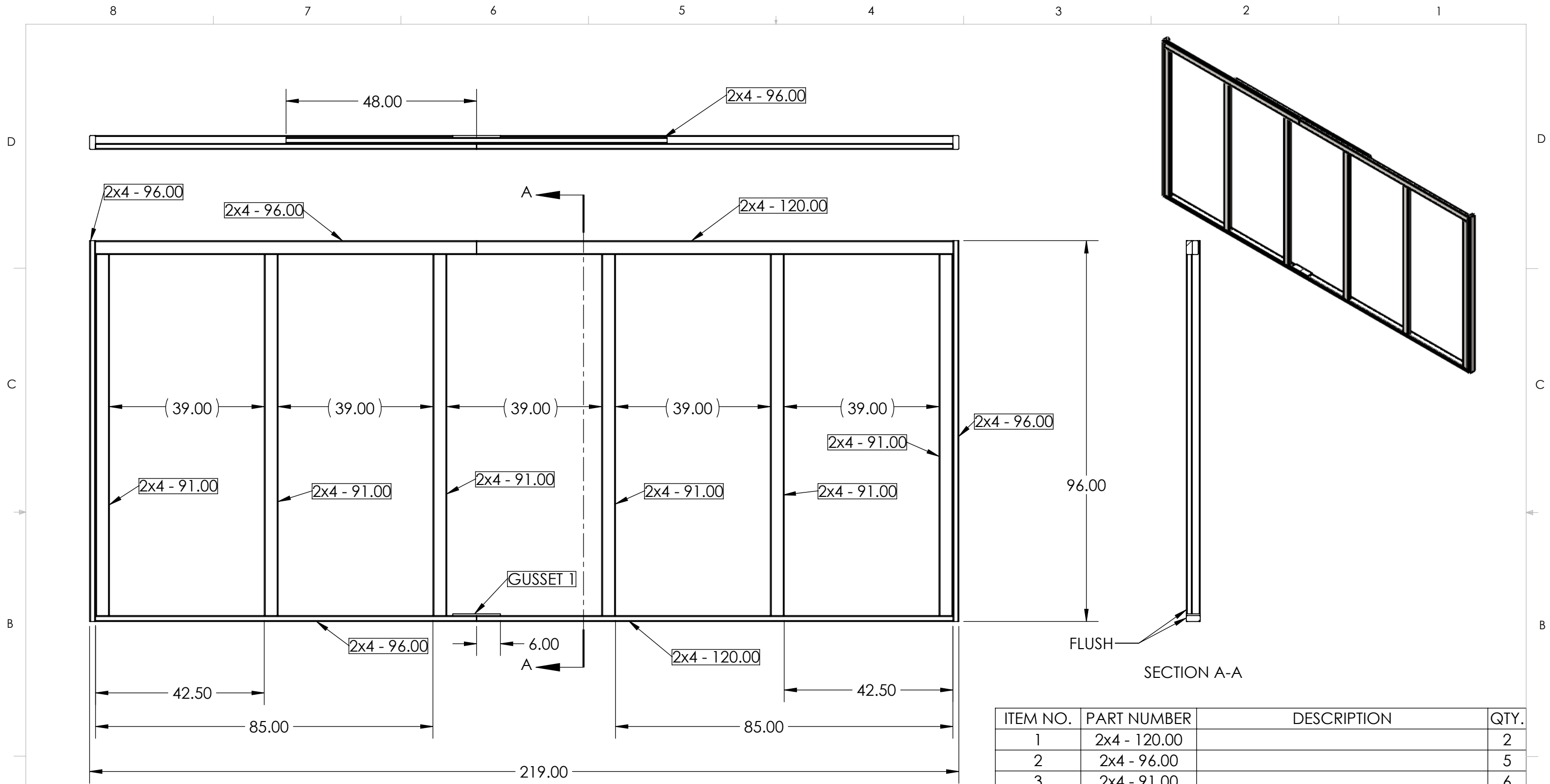

ITEM NO.	PART NUMBER	DESCRIPTION	QTY.
1	2x4 - 120.00		2
2	2x4 - 96.00		5
3	2x4 - 91.00		6
4	GUSSET 1	12.00 X 3.50 X .50	1

UNLESS OTHERWISE SPECIFIED:
 DIMENSIONS ARE IN INCHES
 TOLERANCES:
 FRACTIONAL ± 0.125
 ANGULAR: ± 1 DEG
 TWO PLACE DECIMAL ± 0.030
 THREE PLACE DECIMAL ± 0.010
 DO NOT SCALE DRAWING

INNOVATION BY DESIGN
 TITLE:
 MATERIAL:

PROPRIETARY AND CONFIDENTIAL
 THE INFORMATION CONTAINED IN THIS DRAWING IS THE SOLE PROPERTY OF INNOVATION BY DESIGN AND/OR ITS DESIGNATED CLIENTS. ANY REPRODUCTION IN PART OR AS A WHOLE WITHOUT THE WRITTEN PERMISSION IS PROHIBITED.

	NAME	DATE
DRAWN	SDS	11/13/08
CHECKED		
ENG APPR.		
MFG APPR.		

SIZE DWG. NO. REV
B WALL - BACK **A**
 SCALE: 1:24 WEIGHT: SHEET 1 OF 1

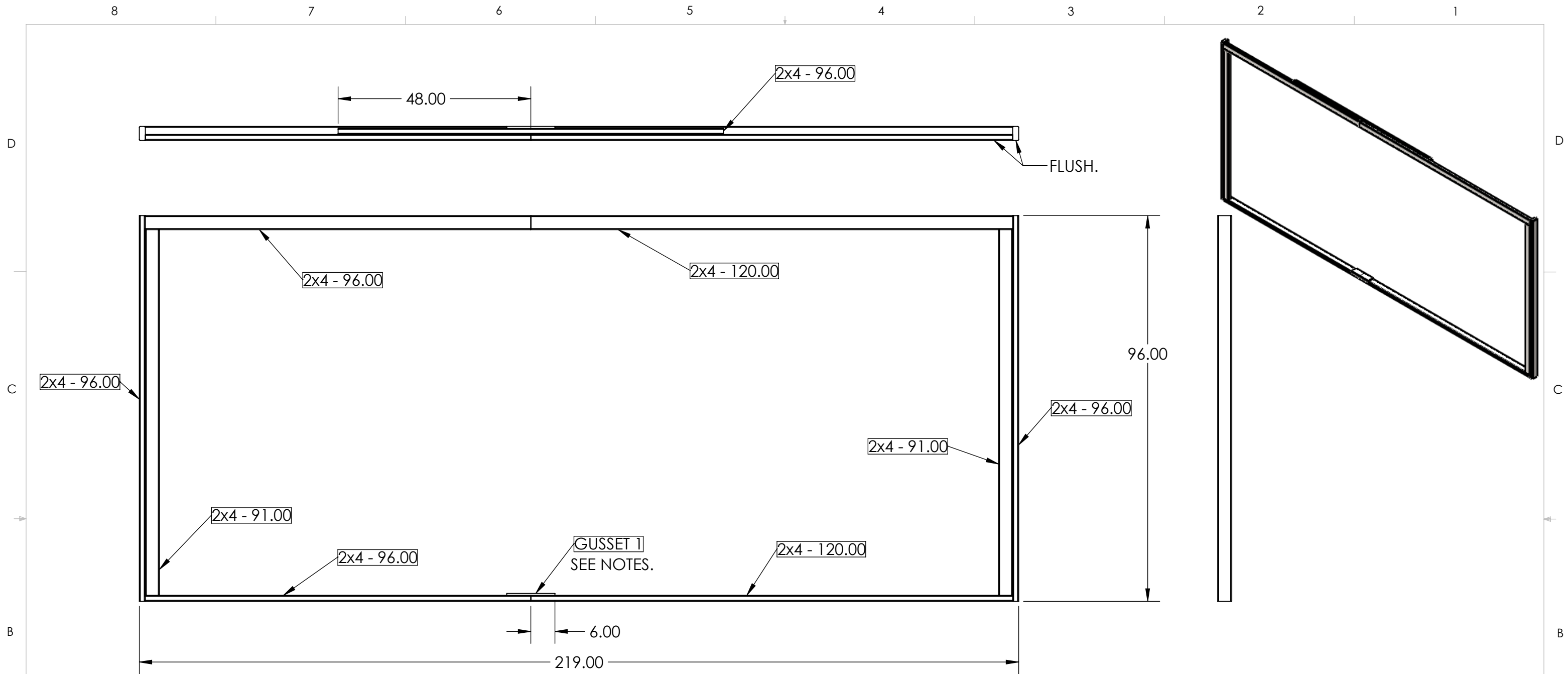

NOTES:

- ON MY OWN BOOTH I USED 3.00 X 6.00 20 GA. STRONG TIE MENDING PLATES (HOME DEPOT SKU #592854) ON BOTH SIDES OF THE BOTTOM 2X4'S INSTEAD OF GUSSET 1.

ITEM NO.	PART NUMBER	DESCRIPTION	QTY.
1	2x4 - 120.00		2
2	2x4 - 96.00		5
3	2x4 - 91.00		2
4	GUSSET 1	12.00 X 3.50 X .50	1

UNLESS OTHERWISE SPECIFIED:
 DIMENSIONS ARE IN INCHES
 TOLERANCES:
 FRACTIONAL ± 0.125
 ANGULAR: ± 1 DEG
 TWO PLACE DECIMAL ± 0.030
 THREE PLACE DECIMAL ± 0.010
 DO NOT SCALE DRAWING

INNOVATION BY DESIGN

TITLE:
 MATERIAL:

PROPRIETARY AND CONFIDENTIAL
 THE INFORMATION CONTAINED IN THIS DRAWING IS THE SOLE PROPERTY OF INNOVATION BY DESIGN AND/OR ITS DESIGNATED CLIENTS. ANY REPRODUCTION IN PART OR AS A WHOLE WITHOUT THE WRITTEN PERMISSION IS PROHIBITED.

	NAME	DATE
DRAWN	SDS	11/13/08
CHECKED		
ENG APPR.		
MFG APPR.		

SIZE	DWG. NO.	REV
B	WALL - OPEN	A
SCALE: 1:24	WEIGHT:	SHEET 1 OF 1

8 7 6 5 4 3 2 1

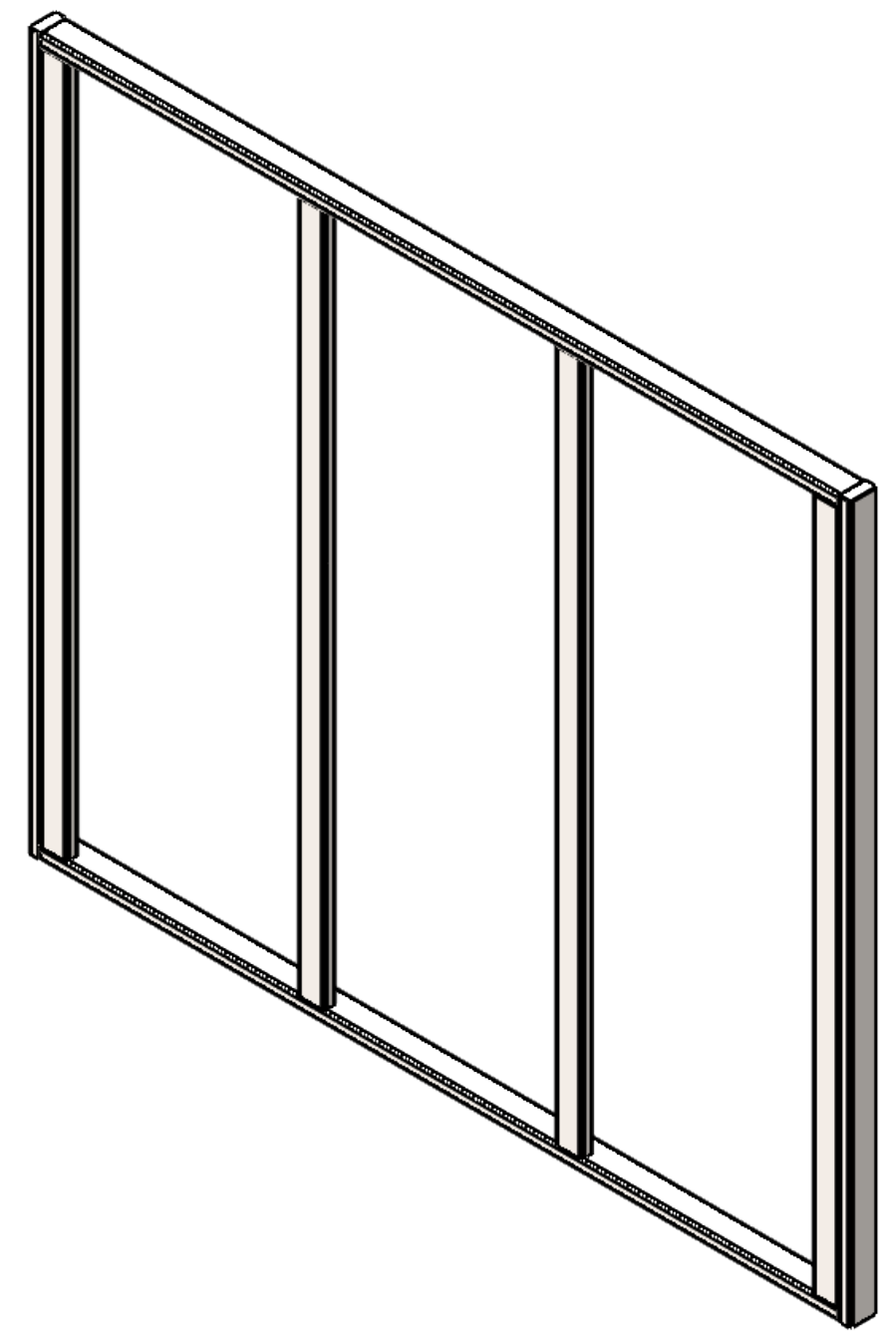
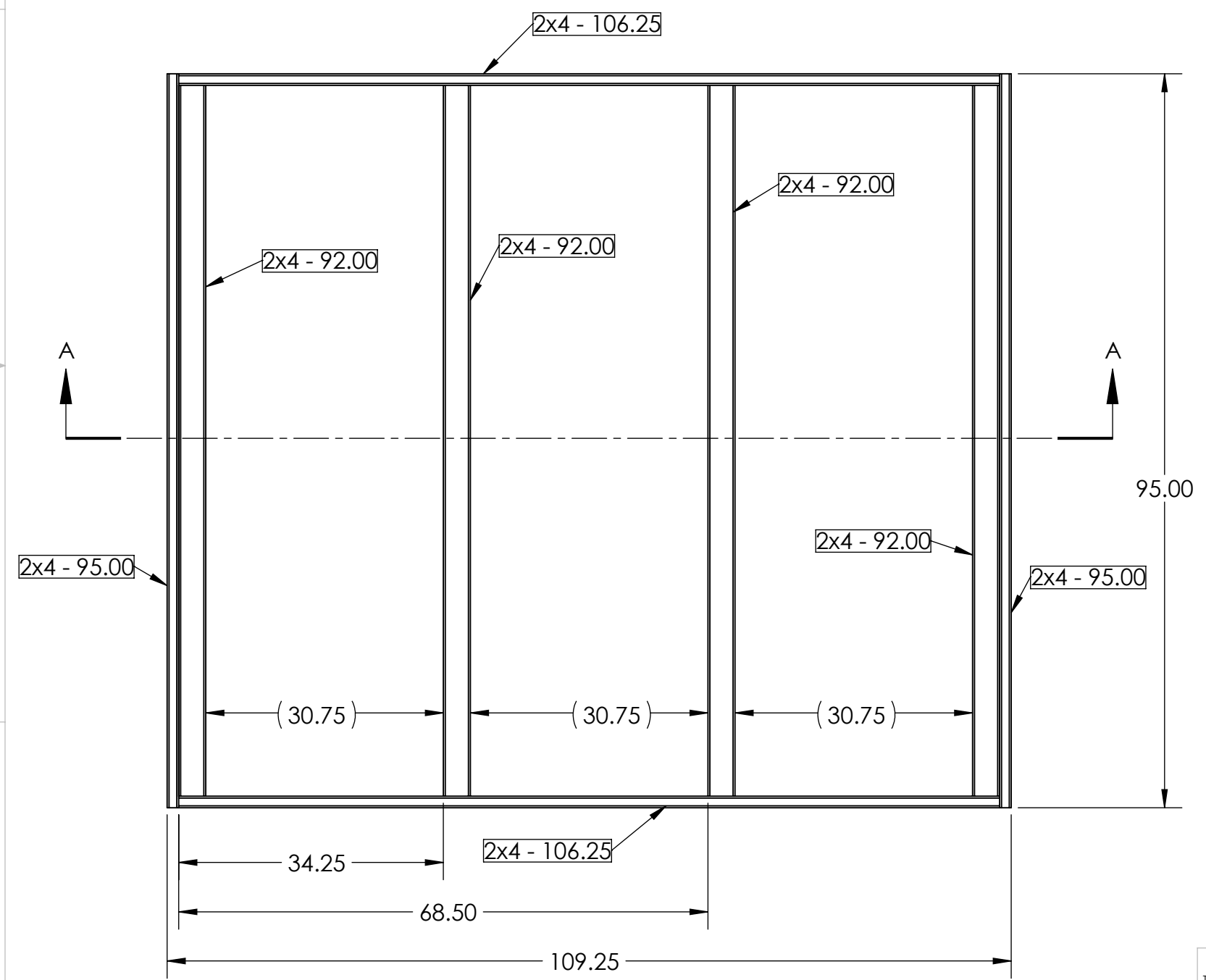
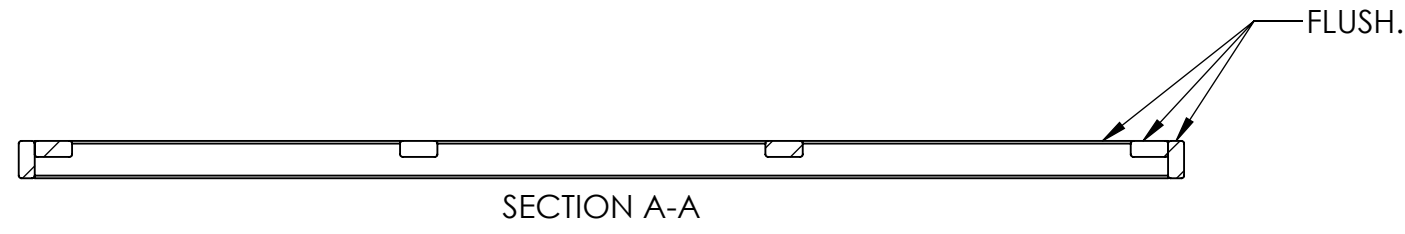

ITEM NO.	PART NUMBER	DESCRIPTION	QTY.
1	2x4 - 106.25		2
2	2x4 - 95.00		2
3	2x4 - 92.00		4

UNLESS OTHERWISE SPECIFIED:
 DIMENSIONS ARE IN INCHES
 TOLERANCES:
 FRACTIONAL ± 0.125
 ANGULAR: ± 1 DEG
 TWO PLACE DECIMAL ± 0.030
 THREE PLACE DECIMAL ± 0.010
 DO NOT SCALE DRAWING

INNOVATION BY DESIGN

TITLE:

MATERIAL:

PROPRIETARY AND CONFIDENTIAL
 THE INFORMATION CONTAINED IN THIS DRAWING IS THE SOLE PROPERTY OF INNOVATION BY DESIGN AND/OR ITS DESIGNATED CLIENTS. ANY REPRODUCTION IN PART OR AS A WHOLE WITHOUT THE WRITTEN PERMISSION IS PROHIBITED.

	NAME	DATE
DRAWN	SDS	11/13/08
CHECKED		
ENG APPR.		
MFG APPR.		

SIZE	DWG. NO.	REV
B	DOOR	A
SCALE: 1:18	WEIGHT:	SHEET 1 OF 1

NOTES:
 1. TWO REQUIRED.

8 7 6 5 4 3 2 1

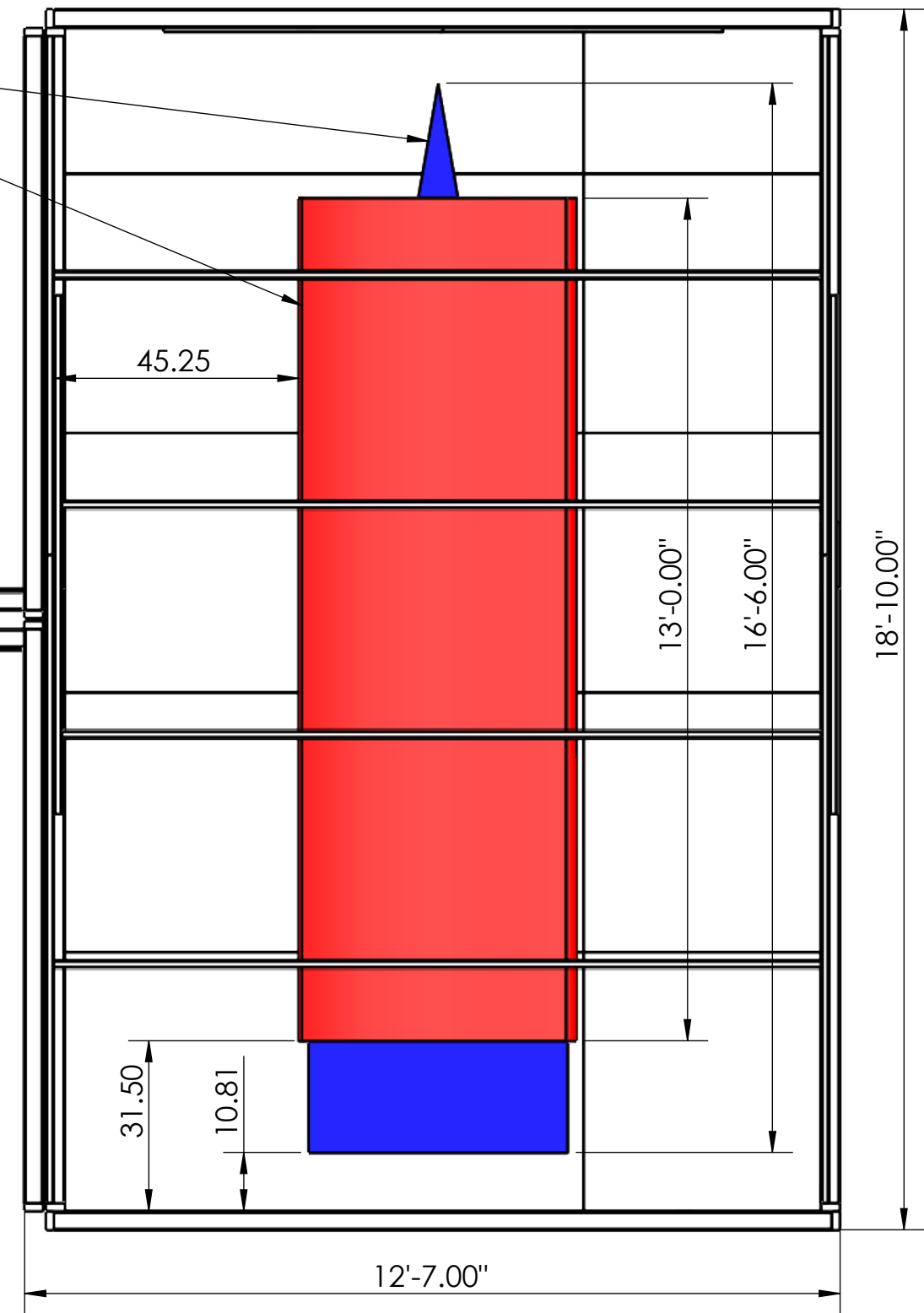
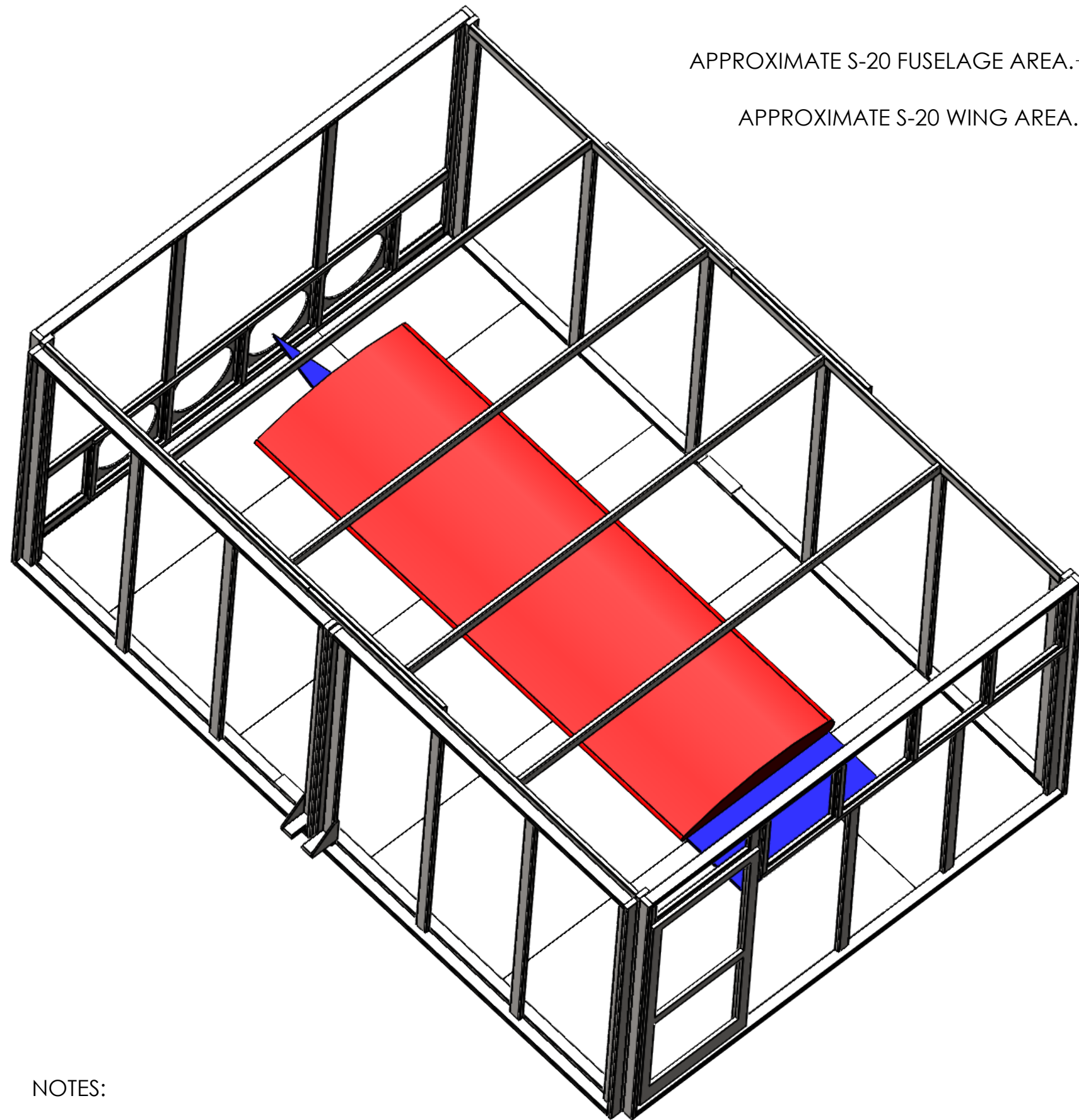

NOTES:

- S-20 COMPONENTS SHOWN FOR APPROXIMATE SIZE REFERENCE.
 - WING = 13 FEET, FUSELAGE IS 16.5 FEET.
 - EXPECT THE ROTISSERIE STANDS TO ADD ANOTHER 6-9 INCHES.
 - IN OTHER WORDS - THE FUSELAGE IS TIGHT, BUT THIS IS THE LARGEST BOOTH THAT WOULD FIT IN MY SHOP. ADD LENGTH IF YOU HAVE THE SPACE.

UNLESS OTHERWISE SPECIFIED:
 DIMENSIONS ARE IN INCHES
 TOLERANCES:
 FRACTIONAL ± 0.125
 ANGULAR: ± 1 DEG
 TWO PLACE DECIMAL ± 0.030
 THREE PLACE DECIMAL ± 0.010
 DO NOT SCALE DRAWING

PROPRIETARY AND CONFIDENTIAL
 THE INFORMATION CONTAINED IN THIS DRAWING IS THE SOLE PROPERTY OF INNOVATION BY DESIGN AND/OR ITS DESIGNATED CLIENTS. ANY REPRODUCTION IN PART OR AS A WHOLE WITHOUT THE WRITTEN PERMISSION IS PROHIBITED.

	NAME	DATE
DRAWN	SDS	11/24/08
CHECKED		
ENG APPR.		
MFG APPR.		

INNOVATION BY DESIGN

TITLE:
BOOTH SIZE APPROX.

SIZE	DWG. NO.	REV
B	BOOTH SIZE	A
SCALE: 1:30	WEIGHT:	SHEET 1 OF 1